

Butterfly valve

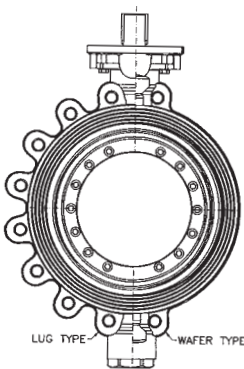

Design:

Wafer-type for fitting between flanges
LUG-type for fitting at end of pipeline.

Double-flanged type. The butterfly valves can be delivered in standard design with a divided shaft, heavy industry and marine design with an undivided shaft. Big valves for heavy duty will be delivered in double-eccentric design

Size:

DN 20 - DN 1400

Operation pressure: up to 30 bar

Flanges:

suitable for or according to DIN 2501
PN6/10/16
ANSI B16.5, class 150

Temperature range: -35 °C / +160 °C (depends on seal)

Materials:

Casing:

Cast iron, spheroidal cast iron, aluminium, cast steel

Disc:

Cast iron, cast steel, bronze, Ni-Al bronze, stainless steel

Replaceable soft seal:

NBR, EPDM, CSM, FPM, VSI, AU

Shaft:

Stainless steel

Actuator:

Hand-lever, handwheel with gear, electric, hydraulic, pneumatic actuator with emergency hand operation

VN - Pumpen

Valves, Instruments, Supervision

Wedge gate valve

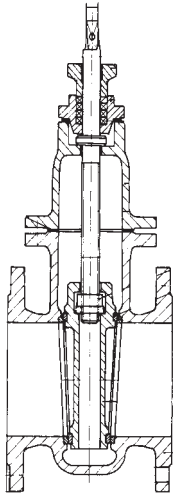

Gate valve with flat body

| acc. to DIN | size DN | pressure range PN |
|-------------|-----------|-------------------|
| 3216 | 40 - 1200 | 2.5/4 |
| 3352 | 40 - 1000 | 1/10 |

Can be delivered with outside screw. Tanker design DN 100 - 600 with handhole door.

Material: cast iron, spheroidal cast iron, CuSn5Pb5Zn5, CuSn10, stainless steel, cast steel

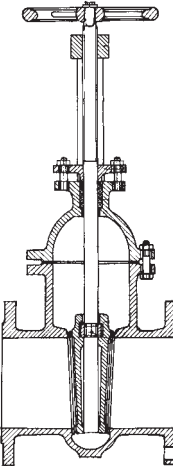

Gate valve with oval body

| acc. to DIN | size DN | pressure range PN |
|-------------|-----------|-------------------|
| 3225 | 40 - 1200 | 10/16 |
| 3225 | 40 - 1200 | 12/25 |
| 3352 | 40 - 600 | 10/16 |
| 3352 | 40 - 500 | 25 |

Can be delivered with outside stem screw.

Material: cast iron, spheroidal cast iron, stainless steel, cast steel

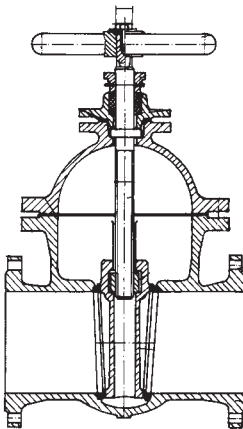

Gate valve with circular body

| acc. to DIN | size DN | pressure range PN |
|-------------|------------|-------------------|
| 3226 | 40 - 400 | 40 |
| 3226 | 500 - 1000 | 25 |
| 3352 | 40 - 500 | 40 |

Can be delivered with outside stem.

Material: spheroidal cast iron, cast steel

General: All valves with hand wheel, on request with indicator, hydraulic or pneumatical actuation, electric actuator, step-down gear

Wedge gate valve

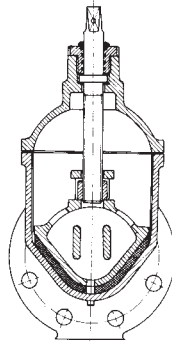
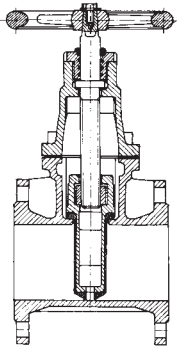

flat or oval body, with rubber coated wedge, spindle with "O"-rings

as specified on page 2, however with internal screwed spindle only, without stuffing box with double "O"-ring seals, flexible sealings on wedge

special quality of perbunan, free passage without gate pocket

Material: casing cast iron

Nominal size: DN 40 - 400

Operation temperature: up to +80 °C

Pressure rating: 10 - 16 bar

Wedge gate valve acc. to DIN 3352

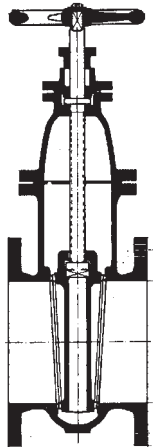

Nominal Size
DN

Nominal Pressure
PN

max operation Temperature
liquids, gases

40 - 500

10

-20 - -400 °C/5 bar

40 - 500

16

-20 - +400 °C/8 bar

40 - 500

25

-20 - +400 °C/13 bar

40 - 500

40

-20 - +400 °C/21 bar

40 - 500

63

-20 - +400 °C/50 bar

Design:

with rising stem through hand wheel; on request with by-pass
Open-close indicator

Material:

Body

Cast steel 1.0619

Trim

Stainless steel 1.4009/1.4021

Wedge valve acc. to ANSI

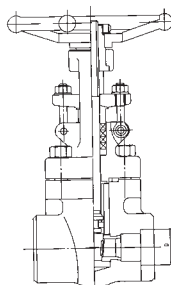
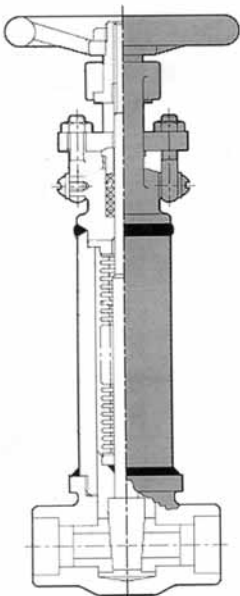

Design to

API 600

Pressure class:

Class 150, 300, 600, 800, 1500

Flange to

B 16.5

Pressure test to

API 598

Face to face dimensions to

ANSI B 16.10

With rising stem

Outside the body

Material:

Body

WCB A 216

Wedge

WCB A 216

Seat

Hard faced on body or

Seat ring

A 105 on request hard faced

Zero (0) - leakage gate valve

Double sealed bellows gate valve

Material: GGG40.3, GS-C25N, 1.4408

Size: flanged DN 15 - DN 150

butt weld ends 15 - 40 mm

Pressure: 50 bar

Flanges: acc.to DIN or ANSI

Same design as described under globe valve page 5.

VN - Pumpen

Valves, Instruments, Supervision

Globe valve as screw-down stop valve

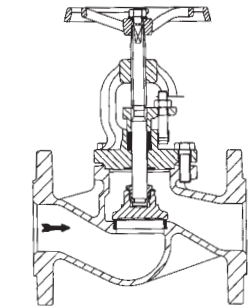

Design: screw-down stop valves corresponding to DIN 86251 with gland seal straight way, angle- or y-pattern

Size: DN 15 - DN 500

Operation pressure: up to 100 bar

Flanges: according to DIN 2501 PN 10, 16, 25, 40, 63, 100 and according to ANSI butt weld ends

Temperature range: -60 / +450 °C

Materials: cast iron, spheroidal cast iron, bronze CuSn5Pb5Zn5, bronze CuSn10, stainless steel, cast steel, forged steel

Optionals: position indicator + non-rotation lock, regulating plug, stroke indicator, locking device, loose plug + spring, balancing plug, limit switches open/close

Actuator: hand wheel, electric, hydraulic or pneumatic

Maintenance-free: by means of double wall bellow seal

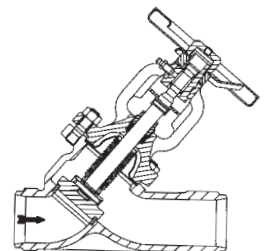
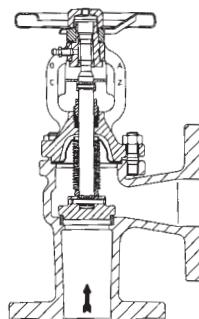
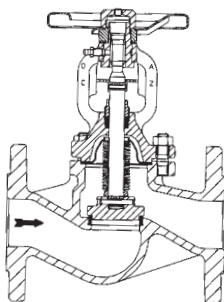
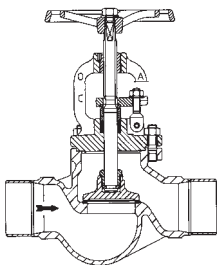
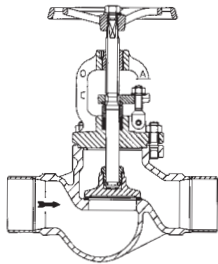
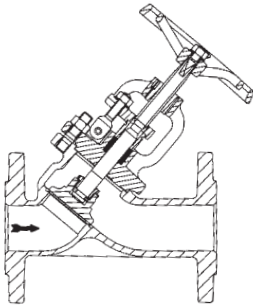

Zero (0) - leakage globe valve

Doubly sealed bellow stop valve straightway or angle pattern. Non-rising spindle, handwheel operated

Material: GGG40.3, GS-C25W, 1.4408

Size: DN 15 - DN 500

Pressure: PN 10, 16, 25, 40

Flanges: acc. to DIN or ANSI

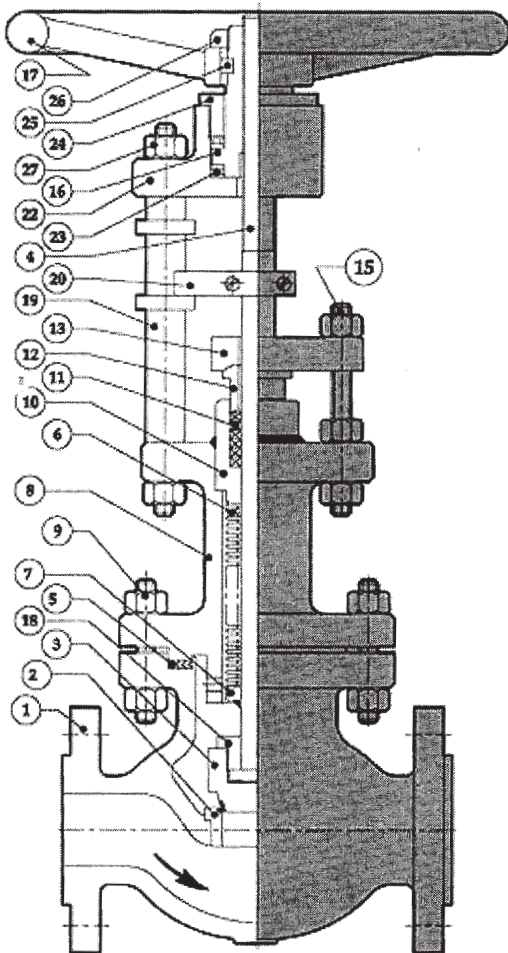

| SR.No. | Parts | material |
|--------|------------------|-------------------------------------|
| 1 | Body | A-216Gr.WBC/ A-352 Gr. LCB LCC |
| 2 | Seat ring | Monel/AISI-316/ Hastalloy-C |
| 3 | Plug | Monel/AISI-316/ Hastalloy-C |
| 4 | Stem | Monel/Hastalloy-C |
| 5 | Gasket | Spiral wound |
| 6 | Bellow | Hastalloy-C-276 |
| 7 | Bellow collar | Hastalloy-C-276 |
| 8 | Bonnet | A-216 Gr. WBC/ A-352 Gr. LCB LCC |
| 9 | Fasteners | A-193 Gr. B8/A-194 Gr. 8 |
| 10 | Stuffing box | Hastalloy-C-276 |
| 11 | Gland packing | PTFE |
| 12 | Gland bush | Hastalloy-C276 |
| 13 | Gland flange | AISI-304/316 |
| 14 | Pillar nut | AISI-304/316 |
| 15 | Gland stud & nut | AISI-304/316 |
| 16 | Yoke sleeve | Ni.Resist |
| 17 | Hand wheel | C.S. fabricated |
| 18 | Stem nut | Monel/AISI-316/ Hastalloy-C |
| 19 | Pillar | AISI-304/316 |
| 20 | Guide plate | AISI-304/316 |
| 21 | Yoke | A-216 Gr. WBC/ A-352 Gr. LCB LCC |
| 22 | Bearing | Std. |
| 23 | Yoke nut | AISI-304/316 |
| 24 | Hand wheel key | AISI-304/316 |
| 25 | Hand wheel nut | AISI-304/316 |

VN - Pumpen

Valves, Instruments, Supervision



Ball valves

Industrial design:

One-piece: reduced bore 1/4" - 2"
or two-part: full bore 1/4" - 3" with inside thread.
Made of stainless steel AISI 316, operation pressure
max. 60 bar, max. temperature 230 °C



With pneumatic actuator,
single or double-acting
with spring loading close



With electric actuator
torque up to 300 Nm



For mounting
between flanges
by studs.

Industrial flange design:

With reduced or full bore

Material: cast steel, forged steel, stainless steel

Actuation: manual, pneumatic, hydraulic or electric

Sizes: DN 4 - DN 1200

Connection: flanges acc. to DIN, ASA, ANSI, welded socket possible

Pressure range: PN 6 - PN 630 and vacuum

Temperature range: -200 °C to +200 °C

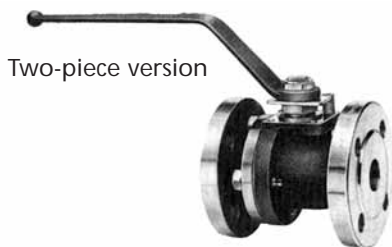

Two-piece version



Three-piece version

3-way ball valves

Possibilities of flow directions at 3-way ball valves with L- or T-bore:
 Position of the ball bores can be checked by milled marks upon the spindle.
 Degree of turn of the hand lever resp. the drive = 90°

| | T-bore | | | | L-bore | | |
|---------------------------------|--------|--|--|--|--------|--|--|
| Hand lever resp. drive assembly | | | | | | | |
| position 0° | | | | | | | |
| position 90° | | | | | | | |

Zero (0)-leakage lift ball valve

Actuation: manual + gear, hydraulic, pneumatic, electric
Material: cast steel GS-C25N, stainless steel 1.4408
Seat: metal to metal, PTFE or any other as requested
Size: DN 150 - DN 500
Flanges: acc. to DIN or ANSI

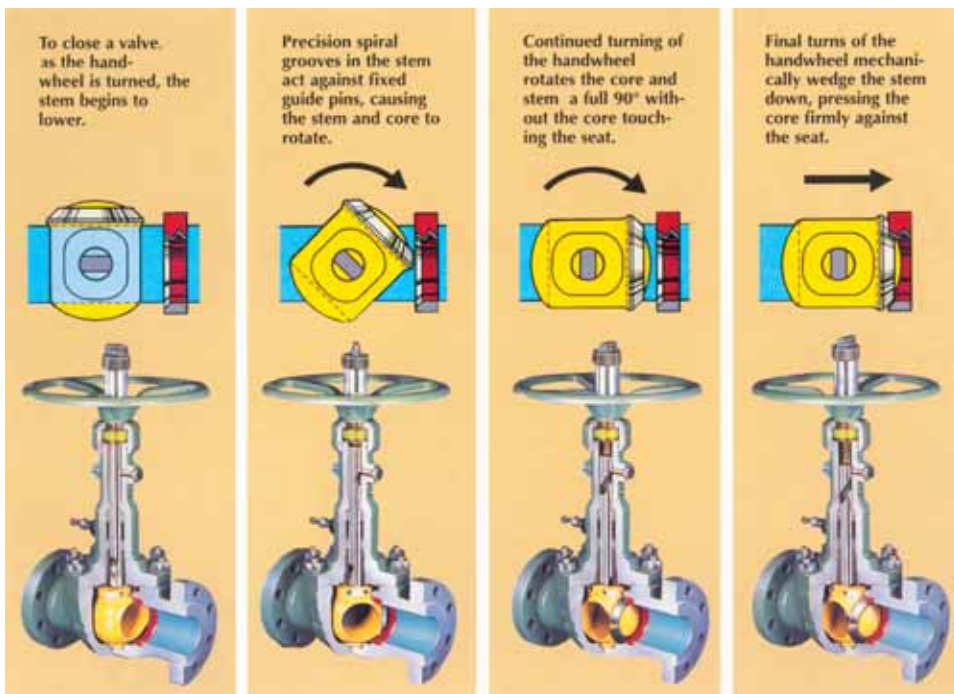

VN - Pumpen

Valves, Instruments, Supervision

Diaphragm – screw- down stop valve

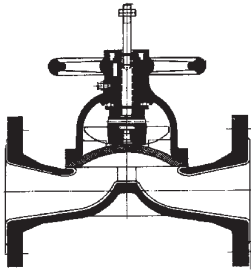

Application: for compressed air, water, gas, fuels and specially for acids and leaching solutions.

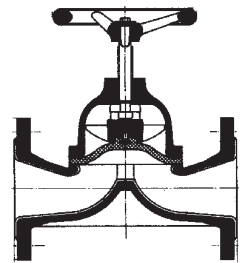

Design: straightway – or angle-design, glandless, without maintenance, with or without rising hand wheel, for vacuum operation with reinforced diaphragm.

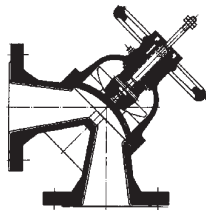

Materials: casing cast iron GG 25, specially recommended inside lining: hard- or soft rubber, PFA and PTFE. diaphragm made of: caoutchouc (natural-, butylene-, EPDM-, nitrile-), chloroprene, hypalone, viton, PTFE

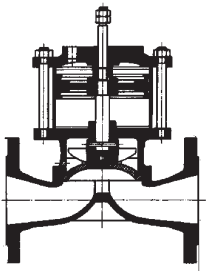

Temperatures: - 20 °C up to + 120 °C, special design up to + 200 °C

Operation pressure: up to DN 150 = 10 bar
up to DN 250 = 6 bar
DN 300 = 4 bar

Driver: hand wheel, chain wheel, power piston action upon both sides or one side with spring, compressed air diaphragm drive, electric actuator.

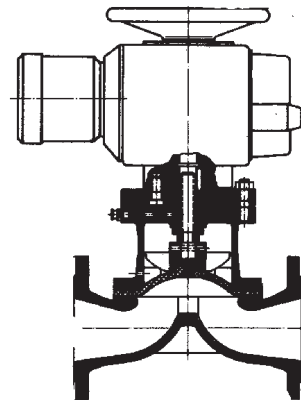
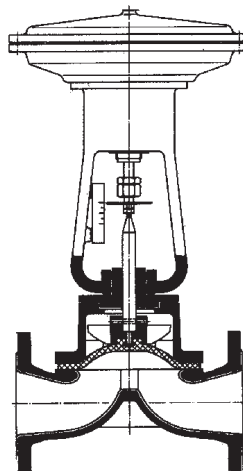

Valves

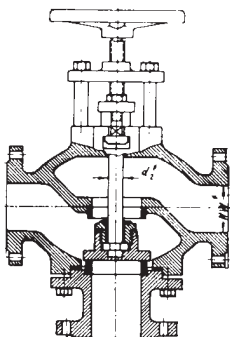

Change-over valve, both sides screwed, made of gun-metal, size 1" – 2½", PN 10, temperature max. 130 °C.

Flange design made of cast iron or cast steel, size DN 20 – DN 200, PN 16 – PN 40

Temperature up to 400 °C



Globe valve, quick closing type, spring-loaded, lever and tow, casing made of cast iron, spheroidal cast-iron, gun-metal or cast-steel, seat and cone made of stainless steel, PN 16 or PN 40, size DN 15 – DN 150, also available with position indicator



Distribution box suction type, made of cast iron with bronze trim, PN 10, 20 °C

Size DN 40 – DN 200, box consists of 2, 3, 4, 5 or 6 valves



Distribution box discharge type,

made of cast iron with bronze trim, PN 10, 20 °C

Size DN 40 – DN 200, box consists of 2, 3, 4, 5, 6 or 7 valves.

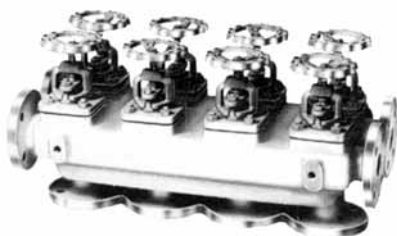

Distribution box combined type,

made of cast iron, with bronze trim.

Suction- and discharge connections above or under the valves. PN 10, 20 °C

Box consists of 2 ranges each with 2, 3, 4, 5 or 6 valves.

VN - Pumpen

Valves, Instruments, Supervision

Knife gate valves



Size: DN 50 - DN 1000
Building length: short 40 - 110 mm
Stem: non-rising
Operation pressure: up to 10 bar
Material:
Casing: cast iron GG 25
stainless steel
1.4401 or 1.4408

Gate: stainless steel 1.4401
Stem: stainless steel 1.4305

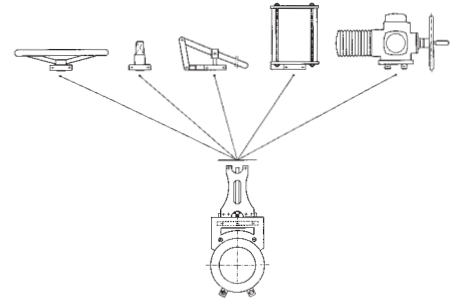

Globe valve self-closing type



With lever and spring
Size: 1/2" - 2"
Casing: G-CuSn5ZnPb

6

Sounding cocks self-closing



Material: G-CuSn5ZnPb
Size: 1 1/2" + 2"
(Sounding cock can be fitted with a 1/4" self-closing test valve.)

Storm valves

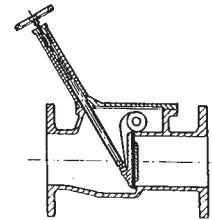
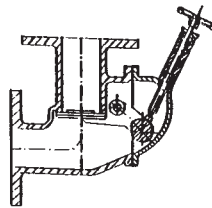
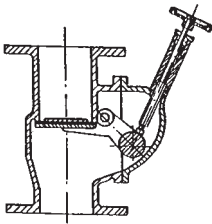

| | | | |
|----------------|---|-----------------------|--------------------------------|
| Design: | Vertical or horizontal. Straight or angle pattern with or without shut-off device | Material: | G-CuSn5Pb5Zn (RG5) |
| Size: | DN40 - DN 200 | Flanges: | acc. to DIN PN 10 |
| | | Test pressure: | casing 10 bar sealing 2 bar |

Outboard valves

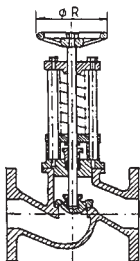

Overboard globe valve, spring-loaded.

Straight or angle pattern. This valve can be opened and closed normally, but it cannot be blocked in the closed position. In that case it is only opened when the pressure under the disc is higher than the pre-set tension of the spring of 0,5 bar.

These spring-loaded outboard valves are designed acc. to the latest prescriptions of the classifications and that in such a manner that it will not be possible to open the disc by means of the stem.



| | |
|----------------------------|--|
| Design: | Straightway or angle pattern |
| Size: | DN 15 - DN 700 |
| Operation pressure: | 4 - 16 bar depending on size |
| Material: | |
| Casing and cone: | cast steel GS-C25, bronze G-CuSn5Pb5Zn5 or G-CuSn10 |
| Stem: | CuAl 10 Ni |
| Flanges: | acc. to DIN PN 16 |

VN - Pumpen

Valves, Instruments, Supervision

Underground fire hydrant acc. to DIN 3221

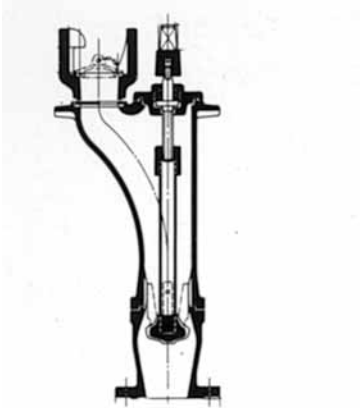

Design:

With automatic drain and pressure water protection.
Single valve disc or with double shut-off.
Casing made of cast iron,
spindle chromesteel,
sealing brass/perbunan
DN 80, DN 100, PN 10
cover depth 0,75, 1,00, 1,25 and 1,50 m

Surface fire hydrant acc. to DIN 3222

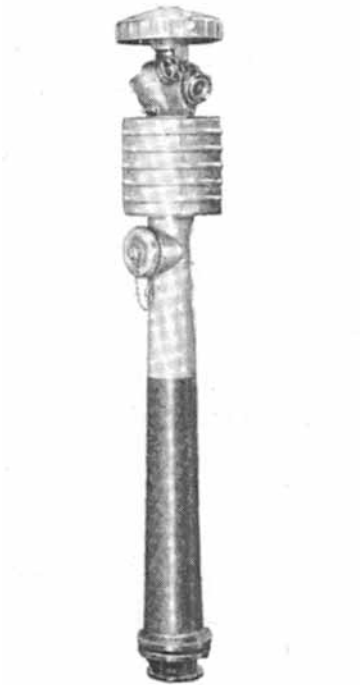

Design:

With automatic drain and pressure water protection PN 10,
casing made of cast iron,
quick-couplings aluminium alloy,
spindle brass
DN 80 with 2 outlets C and 1 outlet B
DN 100 + 150 with 2 outlets B and 1 outlet A
Available with jacket, i.e. the
upper-two outlets can be closed.
Special design with rated breaking point for installation
at high dangerous places, e.g. if hydrant is
rammed the hydrant remains closed.

Road caps



DIN 4055 – for hydrants
DIN 4056 – for water gate valves
DIN 4058 – for gas gate valves
DIN 4057 – for water clamps
DIN 4059 – for gas clamps

Shut-off device made of gunmetal



Screw-down-stop valve, both sides screwed, as inclined seat valve with free passage, heavy industry design, casing made of gunmetal, cover made of special brass Ms 58 (special design gunmetal), nominal pressure PN 16, temperature up to 130 °C or 225 °C depending on sealing, size 3/8" – 3"



Screw-down-stop valve as described above, but flange design, size DN 20 – DN 150



Screw-down-stop valve, DVGW-approved, as inclined-seat valve, both sides with copper joints, sealing conical or flat, with or without drain-cock, casing, screwed cover and solder joints made of gunmetal, nominal pressure PN 16, temperature up to 130 °C, sealing Teflon, with hand wheel, for all copper pipes from 15 up to 89 mm



Screw-down-stop valve as described above, but flanged design, with screwed cover size DN 10 – DN 100 (bigger sizes with bolted cover available), can be delivered also as angle valve

Wedge-gate valve, female screwed ends, screwed cover, available as heavy or light model, casing made of gunmetal or brass, cover made of gunmetal or brass, nominal pressure PN 10, PN 16 or PN 25, temperature max. 130 °C, with hand wheel, size 3/8" – 4"

Wedge-gate valve as described above, but flanged design, size DN 15 - DN 100 with screwed cover (bigger sizes with bolted cover available)

VN - Pumpen

Valves, Instruments, Supervision

Armatures for house-installations

Screw-down stop valves as straight valve, made of brass, acc. to DIN-DVGW, with female ends, 1/2" - 2"

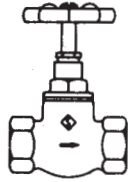

without drain

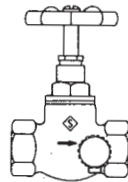

with drain

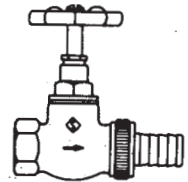

with 1 union

Screw-down stop valves, y-type, with free passage, made of brass, acc. to DIN-DVGW, with female ends, 1/2" - 2"

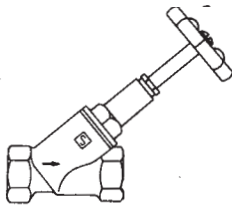

without drain

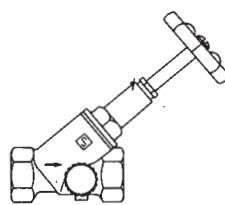

with drain

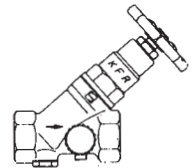

with built-in non-return valve, with test-screw and drain, model "KFR"

Screw-down bib taps, made of brass polished, unpolished or polished chromium-plated, 1/2" - 1"

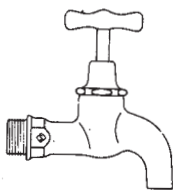

with T-handle

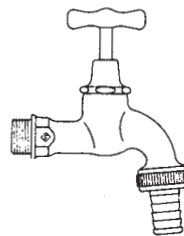

with T-handle and hose union

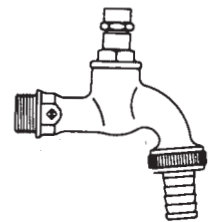

head piece for extra key with hose union

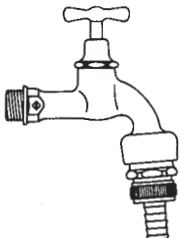

Screw-down bib tap as described before but with aeration device and non-return valve, with hose union



Non-return valve, y-type, made of brass with spring, PN 10, 3/4" - 3"



Non-return valve, with test screw and drain, made of brass, with spring PN 10, 3/4" - 2"

VN - Pumpen

Valves, Instruments, Supervision

Cocks



Plug cocks or gland cocks, material cast iron or gunmetal, straight- or 3-way design, both sides female thread or flanges.

Gas-armatures

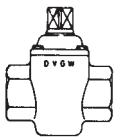

Straight gland cocks
made of brass, both
sides female thread,
 $\frac{1}{2}'' - 2''$

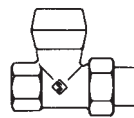

Straight ball valve
for gas, closed
construction, brass-
chromium-plated,
screwed and with 1
union $\frac{1}{2}''$, $\frac{3}{4}''$, $1''$

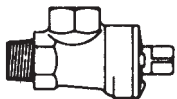

Angle gland cocks
made of brass, both
sides screwed $\frac{3}{4}'' - 1 \frac{1}{2}''$

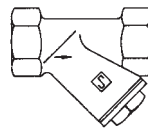

Strainer, y-type,
for gas, made of brass,
with fine-mesh filter
made of hostalen $\frac{1}{2}'' - 2''$

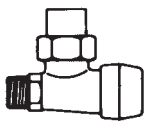

Angle gland cocks
brass-chromium-plated,
screwed and with 1
union $\frac{1}{2}''$, $\frac{3}{4}''$, $1''$

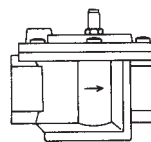

Fine-mesh filter
special model
for gas $\frac{1}{2}'' - 2''$

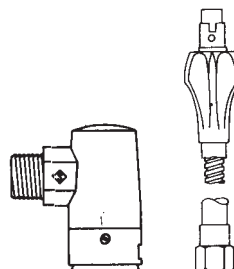

Safety-gas-socket
brass-chromium-plated,
 $\frac{1}{2}''$, screwed, with
safety-gas-hose,
stainless-steel jacketed, 0,5
- 0,8 - 1,0 - 1,25 - 1,5 m

VN - Pumpen

Valves, Instruments, Supervision

Check-and non-return – valves

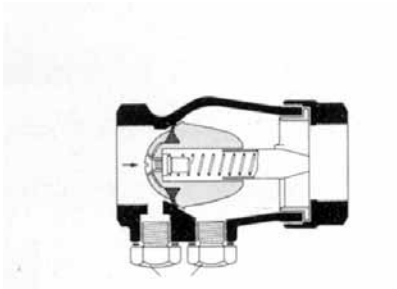

Non-return valve special design for soft closing, structural part approved acc. to DVGW, with test- and drain plug, casing made of brass, inner parts made of plastic and perbunan, for water and compressed air up to 75° C, heating fuel and gasoline from - 20° up to + 60° C, PN 16, 1/2" – 2"

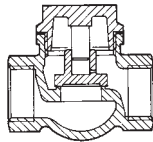

Non-return valve for horizontal installation, with metal seal, made of gunmetal, PN 16, DIN 3845, with inside screw thread 3/8" – 4" (available also with soft special seal) max. temperature 200°C



Non-return valve for vertical installation, with metal seal, made of gunmetal, PN 16, with inside screw thread 3/8" – 4"

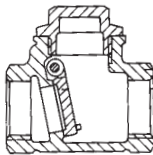

Non-return-flap for horizontal installation, with metallic flap, made of gunmetal, with inside screw thread 3/8" – 2 1/2" max. temperature 185°C



High-pressure non-return valve made of forged steel DN 6 – DN 32, for pressure up to max. 640 bar, with thread connection or welded union



Non-return valve made of plastic for drainage pumps, PN 4, with rubber flap, with inside screw thread 1 1/2" + 2", with drain plug



Foot-valve made of plastic, with strainer, with disc, PN 4, with inside screw thread 1/2" – 2", max. 40 °C



Foot-valve made of cast iron, with strainer made of plastic, with disc, PN 16, with inside screw thread 2" – 4", max. 40 °C

Check-and non-return – valves



Non-return valve for vertical installation, with disc and buffer, made of brass, PN 16, No. 796, with inside and outside screw thread $\frac{1}{2}'' - 4''$, max. 80° C



Non-return valve as described above, but with rubber ball for dirty water, PN 6, No. 852, $\frac{3}{4}'' - 3''$



Non-return valve as described above, but disc and buffer removable, PN 16, No. 860, $\frac{3}{4}'' - 3''$



Angle-non-return valve with upper opening and removable disc and buffer, made of brass, PN 16, No. 861 with inside and outside screw thread, 1" - 2", max. 80° C



Universal non-return valve for horizontal or vertical installation, with spring-loaded disc with rubber sealing, made of brass, PN 16, No. 799, with inside screw thread, $\frac{1}{2}'' - 4''$, max. 80° C



Non-return valve "Silent" for horizontal or vertical installation, with rubber flap, without spring, made of brass, PN 6, No. 857 with inside screw thread $\frac{1}{2}'' - 4''$, max. 80° C



Foot-valve made of brass, with strainer made of brass sheet, with disc and buffer, PN 6, No. 862 with inside screw thread $\frac{1}{2}'' - 4''$, max. 80° C

Foot-valve as described before but with rubber ball and cast strainer, 1" - 3"

VN - Pumpen

Valves, Instruments, Supervision

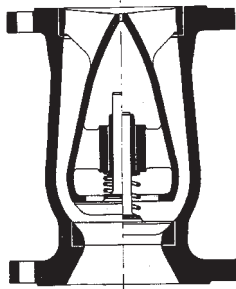

Check-and non-return – valves

Check-nozzle-valve, especially recommended to eliminate water hammer, casing made of cast iron, bronze, stainless steel or cast steel, seat ring and valve disc made of plastic, bronze, NiAl-bronze, stainless steel, flange design, DN 25 – DN 1500, PN 10 – PN 64

In view of these advantages, our valves provide excellent service under all conditions, i.e. during plant shutdowns and power failures etc. They successfully eliminate severe closure shocks and the resultant extensive pipework damage that such shocks can sometimes cause.

Since, when the valve is open, all the important operating parts are protected inside the nozzle ring by the sealing ring, deposits and residues from the water have only a slight effect on the closing operation. This is one of the main reasons for the great reliability and long service life of these valves.

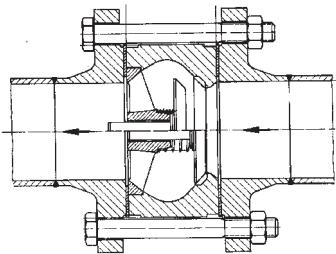

Check-nozzle-valve as described before, but short length for installation between 2 flanges wafer or with flanges, casing made of cast iron or cast steel, seat ring and valve disc made of plastic, bronze or stainless steel DN 25 – DN 200, PN 10 – PN 40

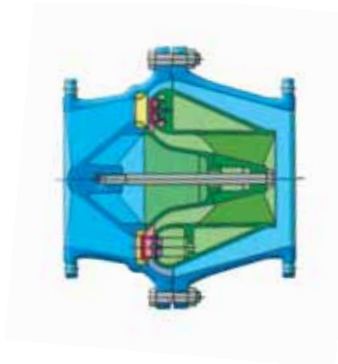

Non-return valve, soft closing, low friction, casing made of cast iron, cast iron coated, bronze, stainless steel. Sealing EPDM or Viton, DN 40 – DN 400, PN 10, 16, 25 and 40 (also available as foot-valve with strainer)

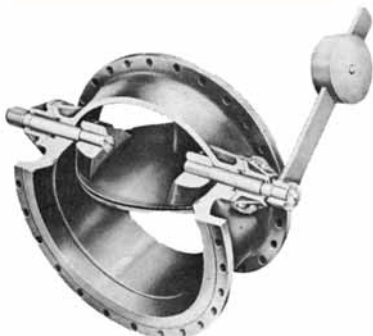

Check- valve as butterfly design, casing and flap made of cast iron, shaft stainless steel, seat ring at casing and flap made of brass, U- and V-rings made of perbunan, weight cast iron, DN 150 – 1500, PN 10 -16

Check- and non-return – valves



Non-return valve, straight valve, casing cast iron, seat and disc and stem chrome steel or gunmetal, flange-construction, PN 16, DN 10 – DN 200 (also available as angle-valve). Max. temperature 200°C

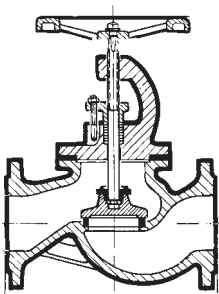

Non-return valve, as described before, but can be closed

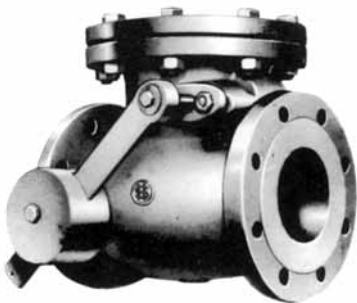

Check valve acc. to DIN 3232, straight valve, casing cast iron, flap shaft stainless steel, sealing rubber to brass or brass to stainless steel, with enclosed flap shaft or one side with external lever and weight, DN 40 – DN 1000, operation pressure range 4 – 16 bar depending on design, size, liquid and temperature.

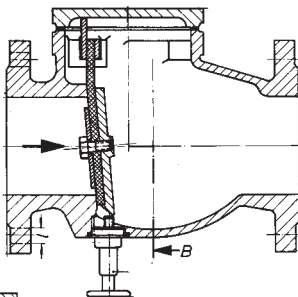

Check valve for sewage with free passage and low friction, can be lifted up, casing cast iron, sealing elements rubber, PN 10, DN 40 – DN 200

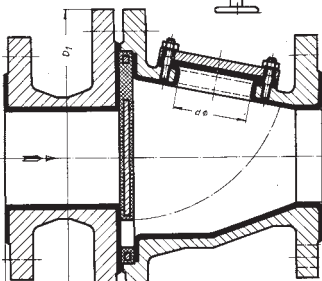

Check valve with free passage and low friction, with cleaning opening, casing cast iron, inside hard rubberised, therefore resistant against many aggressive liquids, DN 80 – DN 200 = PN 16, DN 250 – DN 350 = PN 10

VN - Pumpen

Valves, Instruments, Supervision

Non-return armatures as wafer-type valves

Non-return valve: wafer-type installation between flanges PN 6/10/16/25/40 or acc. to BS or ANSI

Material:

Casing: brass, bronze, cast iron, steel and stainless steel

Inner parts: bronze or stainless steel

Sealing: EPDM for water, steam, condensate
-50° C up to + 150° C FKM for oils, gases, air - 25° C up to + 200° C

Operation pressure: depending on size, model and temperature, 6 bar, 16 bar or up to 40 bar

Size: DN 15 – DN 300

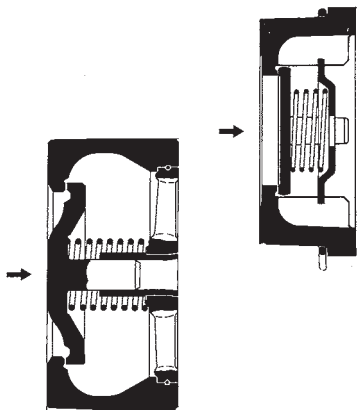

Non-return valve: wafer-type installation between flanges PN6/10/16/25/40

Material:

cast iron, cast iron epoxy coated spherical cast iron stainless steel, closing disc and spring stainless steel, sealing EPDM, FKM

Temperature: up to 130°C

Operation pressure: PN 10, 16, 25

Size: DN 50 - DN 600

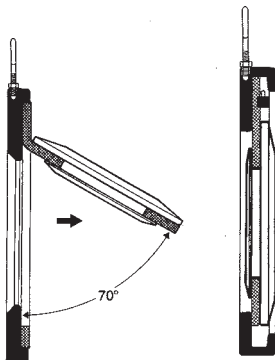

Swing check valve: wafer-type installation between flanges PN 6/10/16/25/40 or acc. to BS or ANSI

Material:

Casing: polyamide, steel plastic coated or galvanized, bronze, stainless steel

Flap: perbunan, bronze, stainless steel

Sealing: EPDM for water, steam, condensate
-50° C up to + 150° C FKM for oils, gases, air - 25° C up to + 200° C

Operation pressure: depending on size, model and temperature, 6 bar, 16 bar or up to 40 bar

Size: DN 50 – DN 300



Recirculation Valves

Automatic recirculation valve

is provided as protection for centrifugal pumps against serious damage from overheating.

Connection: flanges acc. to DIN or ANSI,

Operation pressure: PN 10 – PN 250

Material: casing made of steel or stainless steel, inner parts stainless steel

Size: DN 40 – DN 250

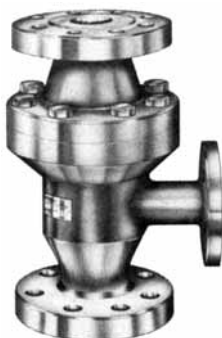

Foot valve

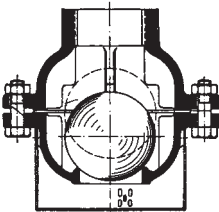
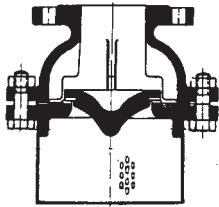

Flanged, with strainer, sealing by cone-disc (special design with rubber ball)

Materials:

Casing: cast iron
 Strainer: steel galvanized, copper-sheet or stainless steel
 Sealing: rubber/iron; rubber/brass; rubber/bronze; brass/brass.

Size: DN 40 – DN 400

Operation pressure: 6 – 25 bar

Temperature: up to 40 °C

Max. flow at 1,75 m/s:

| | | | | | | |
|-------------------|----|----|----|----|-----|-----|
| DN | 40 | 50 | 65 | 80 | 100 | 125 |
| m ³ /h | 8 | 12 | 24 | 32 | 49 | 77 |

| | | | | | | |
|-------------------|-----|-----|-----|-----|-----|-----|
| DN | 150 | 200 | 250 | 300 | 350 | 400 |
| m ³ /h | 111 | 198 | 309 | 445 | 606 | 792 |

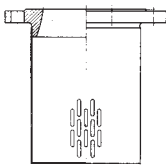

Strainer

Materials:

Upper part: cast iron
 Strainer: steel galvanized or copper-sheet or stainless steel with flange connection or with spring to plug-in into pipe end

Size: DN 40 – DN 1000

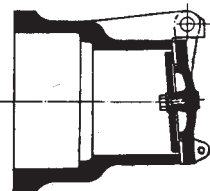

Flap shutter

Application for outlets in reservoirs, channels and high tide shut-off. Casing made of cast iron with following sealing possibilities: cast iron / cast iron; rubber / cast iron; rubber / brass.

Size: DN 40 – DN 1000

Connection to plastic-, cast iron-, steel-, asbestos- or clay-pipe.



Valve boring pipe box

Application for sluiceless boring of main pipe under pressure. For plastic-, cast iron- or steelpipe, with sideways pointed thread connection 1" – 2". Main-pipe dimension DN 50 up to DN 500.

VN - Pumpen

Valves, Instruments, Supervision

Float valves

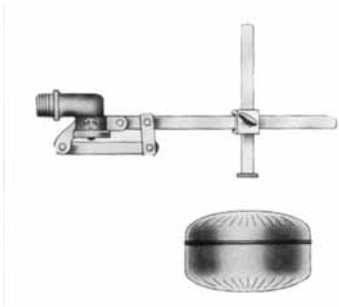

Low pressure float valves for installation in reservoir, made of brass, float made of copper, float spindle for soldering horizontal or vertical adjustable

Operation pressure: 3 or max. 6 bar

Max. temperature: 80° C

Size: 1/2" up to 2"

Size 3/4" available as highpressure model

10 bar = model "Nienstädt"

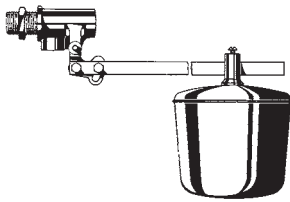

Middle pressure float valves for installation in reservoir, made of brass, float spindle steel galvanized, operation pressure: 6 or 8 bar

Size: 1/2" up to 2 1/2"

Up to 65 °C – with plastic float

Up to 100 °C – with copper float brazed

Float valves, flanged design

Material:

Casing:

cast iron cast steel, gunmetal, stainless steel.

Float:

steel, stainless steel, copper brazed.

Size:

DN 15 – DN 400

Nominal pressure:

PN 6 – PN 64

- Application:**
- for installation in pipelines single seated, not balanced, twin seated or balanced
 - for installation in vessels
 - for installation at tanks
 - for installation on tanks

6

Some installation examples which can be delivered:

float throttle flap

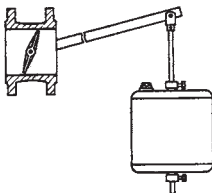

valve for installation in pipeline

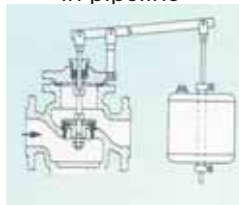

angle inlet valve

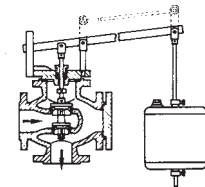

with flange connection

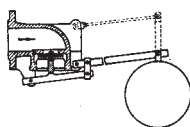

overflow-prevention valve for inflammable liquids

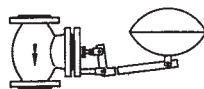

axial leading-out stuffing box

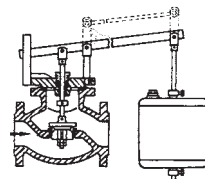

VN - Pumpen

Valves, Instruments, Supervision

Aeration valves

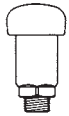

Aeration valve, brass-chromium-plated 1/2"



Aeration device, straight type, flow direction from top to bottom, brass-chromium-plated 1/2", 3/4", 1"

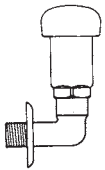

Aeration valve, brass-chromium-plated 1/2", with rear elbow



Aeration device as described before, but with built-in check valve, 1/2"

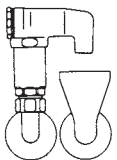

Aeration valve, brass-chromium-plated, with dipping water regulation, elbow union and throat, 1/2" x 3/4" or 3/4" x 3/4"



Aeration valve for liquid-filled discharge pipes, casing: steel galvanized float: stainless steel size: DN 80 + DN 100 nominal pressure: 10 bar

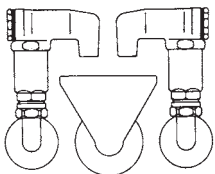

Aeration valve as described before, but double, with common throat



Aeration valve, made of cast iron, float made of stainless steel, flange connection, size DN 25 + DN 50, nominal pressure PN 16 + PN 25, max. temperature 40 °C

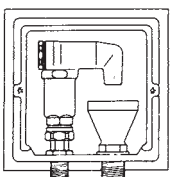

Aeration valve as described before, but single or double built-in frame cover made of chrome-nickel-steel dull

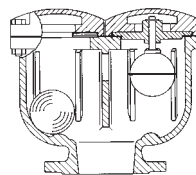

Aeration valve as described before, but as double valve, DN 50/80/100/150/200, PN 10/16/25, also available with fixed hand wheel for maintenance without interruption of operation



Continuous bleeding venting valve
DN 32 - DN 100
PN 16 - PN 40

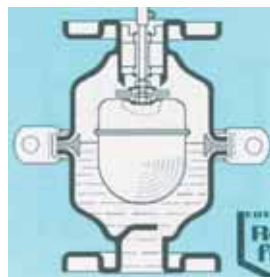

start-up bleed valve
DN 25 - DN 100
PN 16

VN - Pumpen

Valves, Instruments, Supervision

Diaphragm safety valve

spring-loaded, structural type tested

Material: brass or gunmetal

Size: R 1/2" up to R 1 1/4" with enlarged outlet
R 1" up to R 2"

Adjustable pressure: 1 up to 10 bar

Adjusted pressure: 2,5 / 6 / 10 bar, not adjustable

Cone can be lifted up, by cap
2,5 bar for closed heating system, 6 and 10 bar for pressure resistant warmwater boiler acc. to regulations.
Lead-sealed against unauthorized adjustment.

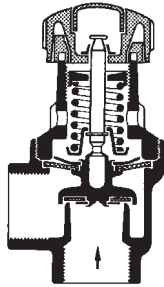

Full-lift safety valve

Spring-loaded, can be delivered with test "T.Ü.V".

Material: gunmetal, sealing perbunan, spring stainless steel

Adjustable range: for water and neutral liquids up to 130 °C, 0,5 up to 16 bar,
for air, neutral gas and steam up to 225° C, 0,5 up to 25 bar

Size: R 1/2" up to R 1 1/4", with enlarged outlet R 1" up to R 2"

Design bF: O-ring gasket made of EPDM, spring of bronze for inflammable and toxic liquids up to 150°C, oil, gasoline and kerosene included



Blow off capacity at 10 % pressure exceeding for water l/h:

| bar | 2 | 4 | 6 | 8 | 10 | 12 | 14 | 16 |
|--------|-------|-------|-------|-------|-------|-------|-------|-------|
| 1/2" | 3310 | 4680 | 5670 | 6630 | 7410 | 8880 | 10370 | 11850 |
| 3/4" | 7450 | 10530 | 12900 | 14890 | 16650 | 18230 | 19700 | 21060 |
| 1" | 13260 | 18750 | 22970 | 26520 | 29650 | 32470 | 35070 | 37500 |
| 1 1/4" | 25980 | 36750 | 45000 | 51970 | 58970 | 63620 | 68730 | 73750 |

Ordinary safety valve and relief valve

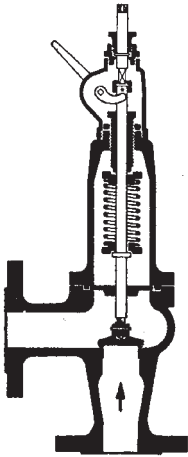

Inlet and outlet = same dimension

- Application:** water, seawater, air, oil and steam
- Design:** angle- or straight-way model, spring-loaded with open or enclosed spring; if required weight-loaded model available
- Material:** casing: cast iron or cast steel, inner parts: stainless steel or gunmetal
- Size:** DN 15 up to DN 200
- Temperature range:** up to 180° C

Full-lift safety valve

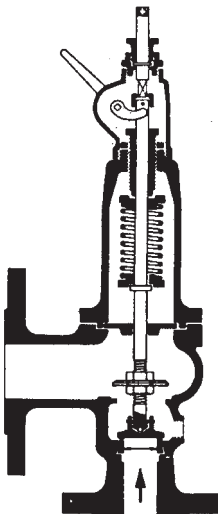

With enlarged outlet, structural part approved acc. to rules of "TÜV"

- Application:** water, gas, steam
- Design:** angle- or straight-way model, spring-loaded with open or enclosed spring; if required, weight-loaded model available
- Material:** casing: cast iron, cast steel, stainless steel, inner parts: stainless steel
- Size:** DN 20 - DN 250
- Temperature range:** up to 400° C
- Certificate:** can be delivered with test of "TÜV"

VN - Pumpen

Valves, Instruments, Supervision

Pressure-reducing valve

with **balanced** disc, with incorporated filter

Application: water and compressed air max. 40 °C

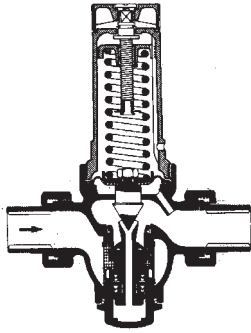

Design:

| | normal version | high pressure version | low pressure version |
|--------------------|----------------|-----------------------|----------------------|
| Inlet pressure bar | | | |
| R 1/2" + 3/4" | 2,5 - 25 | 2,5 - 25 | 1,2 - 25 |
| R 1" up to 2" | 2,5 - 16 | 2,5 - 16 | 1,2 - 16 |

Outlet pressure bar

| | | | |
|---------------|---------|----------|---------|
| R 1/2" + 3/4" | 1,5 - 6 | 1,5 - 12 | 0,5 - 2 |
| R 1" up to 2" | 1,5 - 6 | 1,5 - 12 | 0,5 - 2 |

Min. pressure gradient bar

| | | |
|---|---|---|
| 1 | 1 | 1 |
|---|---|---|

Max. reduction ratio

| | | |
|------|------|------|
| 10:1 | 10:1 | 20:1 |
|------|------|------|

Materials:

| | |
|------------|--------------------|
| casing: | brass or gunmetal, |
| diaphragm: | perbunan |
| strainer: | stainless steel |

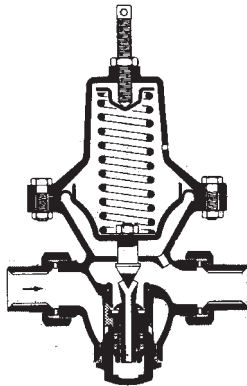

Pressure-reducing valve

With **unbalanced** disc and **balanced** disc

Application: compressed air up to 70° C

Design:

- inlet pressure 3 - 50 bar, outlet pressure 1,5 - 25 bar, min. pressure gradient 1,5 bar, max. reduction ratio 15:1
- inlet pressure 1,8 - 40 bar, outlet pressure 0,2 - 2 bar, min. pressure gradient 1 bar, max. reduction ratio 20:1
- with balanced disc: inlet pressure 2 - 50 bar, outlet pressure 1 - 10 bar, min. pressure gradient 1 bar, max. reduction ratio 10:1, with thread-socket, with connection for pressure gauge

Materials: gunmetal or brass

Size: R 1/4" bis R 2"

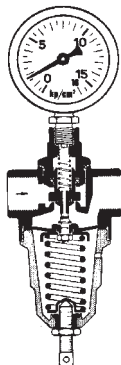

Pressure-reducing valve

with balanced disk

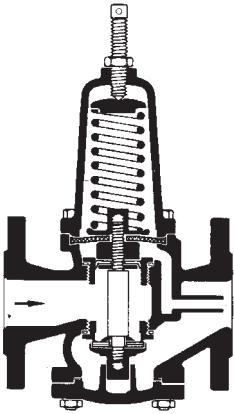

Application: water up to 75 °C, compressed air and nitrogen up to 70 °C, light fuel oil, non-acid mineral oil up to 60° C

- Design:**
- a) inlet pressure 3 – 40 bar, outlet pressure 1,5 – 6 bar, min. pressure gradient 1,5 bar, max. reduction ratio 10:1
 - b) inlet pressure 1,2 – 40 bar, outlet pressure 0,2 – 2 bar, min. pressure gradient 1,0 bar, max. reduction ratio 20:1
Flange-model with connection for pressure gauge

Materials:

Casing: gunmetal (DN 15 – DN 32), cast iron, graphite spheroidal cast iron (DN 40 – DN 200)

Inner parts: gunmetal, bronze, stainless steel

Diaphragm: perbunan

Size: (DN 15 – DN 200)

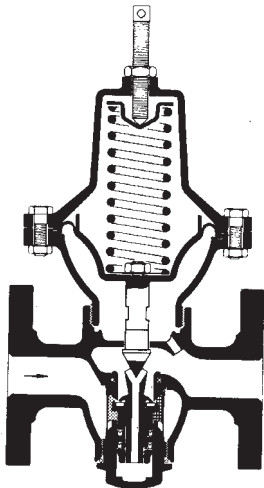

The use of a strainer before the pressure reducing valve is recommended.

Pressure-reducing valve for steam

Material cast iron:

inner parts:
stainless steel for steam up to 300° C and inlet pressure up to 13 bar (gauge pressure, saturated steam), outlet pressure 1,5 – 11 bar, max. reduction ratio 10:1
alternative: outlet pressure 0,3 – 11 bar, max. reduction ratio 25:1

Material cast steel:

inner parts:
stainless steel for steam up to 400 °C and inlet pressure up to 32 bar (gauge pressure, saturated steam), outlet pressure 1,5 – 21 bar, max. reduction ratio 10:1
alternatively: outlet pressure 0,3 – 21 bar, max. reduction ratio 25:1

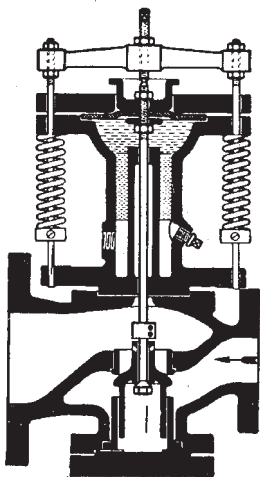

Size: DN 15 – DN 200

VN - Pumpen

Valves, Instruments, Supervision

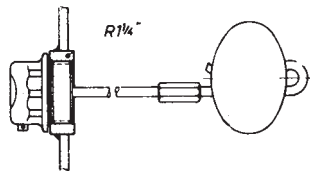
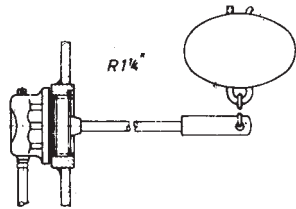
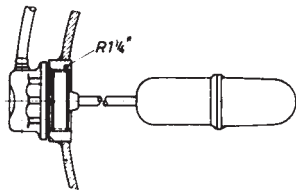

Pressure-tank air-content control device

“Luftwart” has to be used for automatic control of the air content of a pressure tank in connection with a piston-type pump or a self-priming centrifugal pump. Air content is maintained on the optimum level for the system under assumption that a min. suction lift of 2 m is available.

“Luftwart” can be installed on the vertical or horizontal pressure tank.

In case of excess air (for example untight suction line or too high vacuum) another model of “Luftwart” is used as a venting device.

Compressed air-stop valve

Compressed air-stop valves are to be used for pressure tanks on by-pass, i.e. common inlet and outlet of the valves stop the flow of the compressed air from the pressure tank to the system.

For example: when the pressure tank becomes empty because of following reason: water consumption on system is higher than pump capacity or the pump has failed.

Model DLS/A for installation on the bottom of the tank with special flange DN 50 – DN 200

Model DLS/B flanged connection on side, further as described above

Model DLS/ES screwed connection on the side for installation in a pressure tank acc. to DIN 4810, further as described above

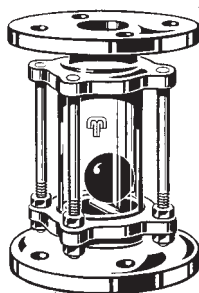
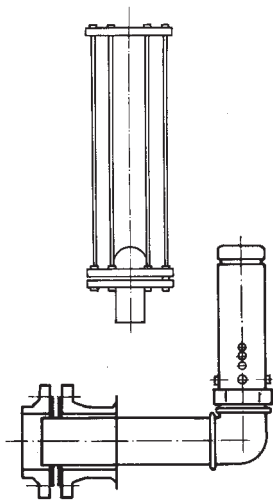

Sight glasses, double sided, with flanges for vertical pipelines with downward and upward flow and for all horizontal pipelines.

For water, oil, fuel oil etc.

Temperature up to 120 °C, special design up to 180 °C.

Casing made of cast iron with heat-treated glass.

DN 20 up to DN 150 = max. 10 bar

DN 175 up to DN 450 = max. 6 bar

Thread-version up to 1 1/4" and flange version up to DN 65 available in gunmetal.

Strainers

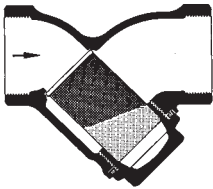

Strainers, screwed ends 1/4" up to 2" for water. Oil and compressed air up to 16 bar, steam up to 6 bar and 160 °C. Casing made of brass or gunmetal.

The strainer is a wide-meshed stainless steel screen rolled into the shape of a cylinder and fitted with a fine-meshed stainless steel gauze screen.

Available, with different mesh sizes of the gauze screen (i.e. 0,6 – 0,35 – 0,18 mm) and with double screen.

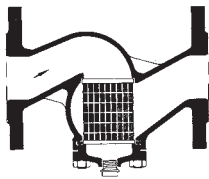

Strainers

with flanges DN 15 up to DN 300 for water, oil and compressed air following pressure limits PN6, PN 16 and PN 40. For steam 2,5 bar/200° C, 12 bar/225° C, PN 40 acc. to DIN 2401. Casing cast iron, cast steel, forged steel, bronze, stainless steel strainer element and screen made of stainless steel.

Available with different mesh sizes of the gauze screen (i.e. 0,8 – 0,5 – 0,25 mm) and with double screen.

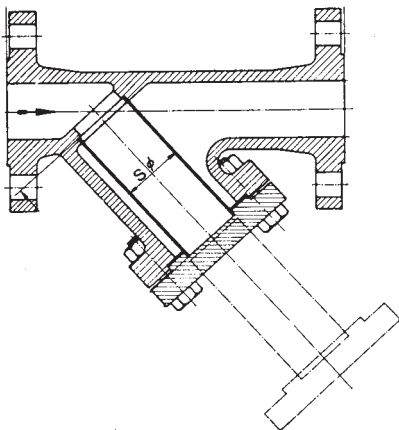

strainers as described before, but "Y"-version

Mud boxes

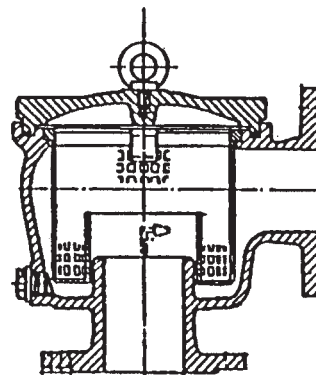
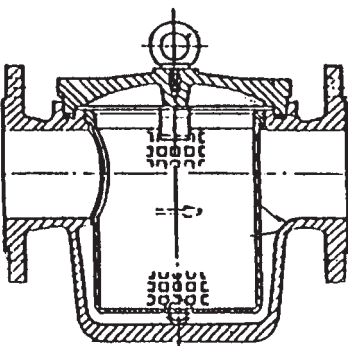

Mud boxes (also called coarse filter) acc. to DIN 87151.

straightway:
angle pattern:
Casing:
Basket:

DN 15 - DN 400, PN 2,5
DN 32 - DN 300, PN2,5
cast iron, Rg 5, Rg 10 or bronze.
steel galvanized, brass MS 63, stainless steel 1.4301 or 1.4571 or CUNI 10Fe 2.08872.10

VN - Pumpen

Valves, Instruments, Supervision

Liquid level indicator

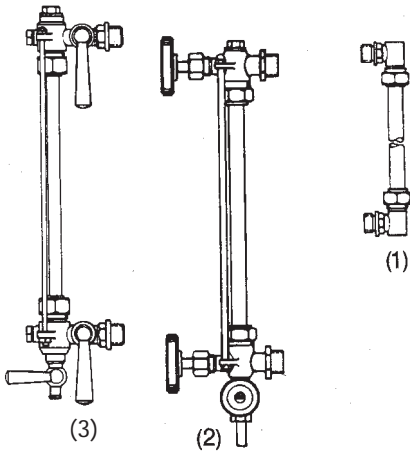

Level indicator (1) made of brass, without screw-down valves, with screwed connections, PN 16, 1/2", for max. temperature of 90 °C (can also be used for oil)

Level indicator, normal design (2) made of brass, with screw-down valve at top and bottom, with screwed connections, PN 16, 1/2", for max. temperature of 90° C,

with drain cock and upper connection possibility for pressure gauge. Indication tube made of celluloid.

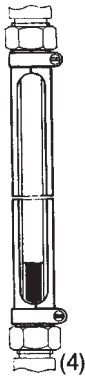

Level indicator – strong industry- and ship-construction (3) Made of brass or gunmetal polished and stainless steel 1.4571, with screw-down valve at top and bottom, PN 16, 1/2", 3/4", 1" or 1 1/4" with drain cock and upper connection possibility for pressure gauge. Indication tube made of celluloid or glass, with protection rods made of brass.

Unit available with intermediate pieces for longer indication lengths.

Instead of protection rods we can deliver protection tube with observation slit (4).

Also available self-closing version with press button or through dead weight; flange connection instead of screwed connection possible.

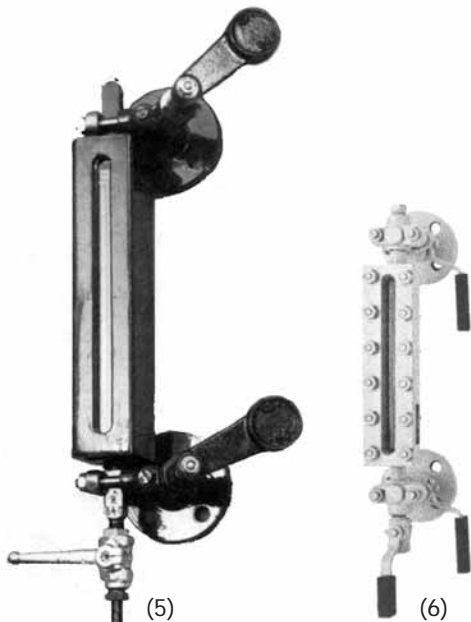

Water level indicator for steam boiler (5 + 6) with self-closing valves.

Casing made of forged steel or special bronze for pressure range PN 25, PN 40 or PN 64, with flange connection, flange diameter normal 105 mm, quick-closing valve for left- or right hand. Reflex-glass holder turn-up, glasses easily changeable, width 34 mm, glass thickness 17 mm, glass length 165, 180, 220, 250, 280, 320, 340, 370, 400, 430, 460 and 500 mm

Accessory-armatures



pressure gauge 3-way cock, made of brass, with plastic handle, both sides thread socket, 1/2", PN 25, with stuffing box



tankfill- and drain-cock, made of brass or gunmetal, with stuffing box, hose union, cap and chain, 1/2", 3/4", 1"



pressure gauge 3-way cock as described before but thread socket / external thread



tankfill- and drain-valve as described before, but as ball-valve



pressure gauge push-button valve, with control piston and return spring, both sides thread socket, 1/2", PN 25



cone straight cock with union, made of gunmetal, 1/4" - 1 1/2"



pressure gauge control-3-way cock, made of brass with plastic handle, clamping socket / external thread, with test-flange, 1/2", PN 25



cone drain cock, made of gunmetal, 1/2" - 1"



high pressure gauge valve, made of brass, with drain, test-connection, 1/2", PN 250 (also available up to PN 630, material stainless steel)



shock absorber for pressure gauges made of brass, steel, stainless steel 1/2"



water sack tube, made of steel, with male thread, 1/2", PN 25



air screw with screw wheel, made of brass ", 1/8, 1/4", 3/8"



air sniffing valve, made of brass, with rubber lip, 1/4", 3/8", 1/2"

VN - Pumpen

Valves, Instruments, Supervision

Accessories for compressed air stations



Non-return valve, straight version
made of brass $\frac{1}{4}'' - 1''$, PN 16,
with sealing made of perbunan, EPDM or viton
for temperatures up to 180 °C,
opening pressure min. 0,1 bar $\frac{3}{4}'' + 1''$,
min. 1,0 bar $\frac{1}{4}'' + \frac{1}{2}''$



Shut-off valve, straight version
made of brass and gunmetal, $\frac{3}{8}'' - 3''$, PN 16,
sealing PTFE for temperatures up to 150° C
needle valve made of stainless steel
 $\frac{1}{8}'' - 1''$ up to 350 bar



Condensate drain cock $\frac{1}{4}''$ or $\frac{3}{8}''$



Automatic drain valve for trap actuated by pressure switch



Oil-and water separator

PN 16, with plastic-vessel for temperature up to 50 °C,
with metal-vessel for temperature up to 60°C, $\frac{1}{4}'' - 2''$



Maintenance station:

filter, pressure reducer and oiler in one unit,
with plastic vessel for temperatures up to 60 °C, 16 bar
with metal-vessel for temperature up to 60 °C, 20 bar
with drain valve manual $\frac{1}{4}'' - 1''$

Hose, $\frac{1}{2}''$ up to 2'' with ready-mounted connection pieces,
PN 16



Coupling, automatical closing, one side for hose, the other
side thread connection, $\frac{3}{8}'' - \frac{3}{4}''$



Hose-coupling automatical closing
6, 8, 9, 10, 13, 16 and 19 mm.

For compressed air fittings please ask for special catalogue.

Safety-valve, pressure reducer, ball-valve, pressure gauge, pressure switch, flexible mounting can be found elsewhere in our catalogue.

Automatic continuous TDS control system

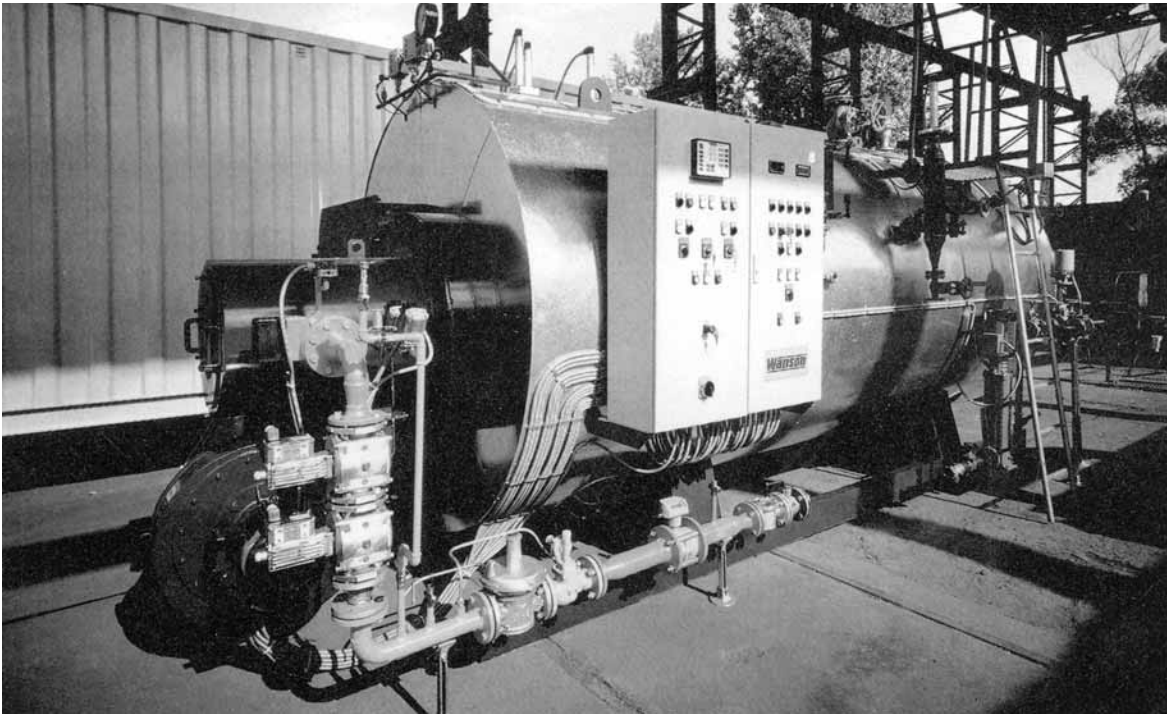

The Automatic Continuous Boiler Blowdown System fulfils two functions: Firstly, the conductivity is controlled precisely. Secondly, the boiler water TDS are kept at the optimum level (TDS = Total Dissolved Solids)

This ensures full safety and avoids:

Insufficient blowdown resulting in:

- Waterside scale formation
- Carryover of boiler water with steam
- Damage to turbines and superheaters
- Fouling of heat exchangers
- Blocked steam taps
- Contaminated production

Excessive blowdown resulting in:

- Wasted energy
- Loss of water treatment chemicals
- Excessive make-up water usage
- Effluent disposal problems
- Accelerated erosion of blowdown piping

VN - Pumpen

Valves, Instruments, Supervision

Automatic continuous TDS control system

Overall System Arrangement

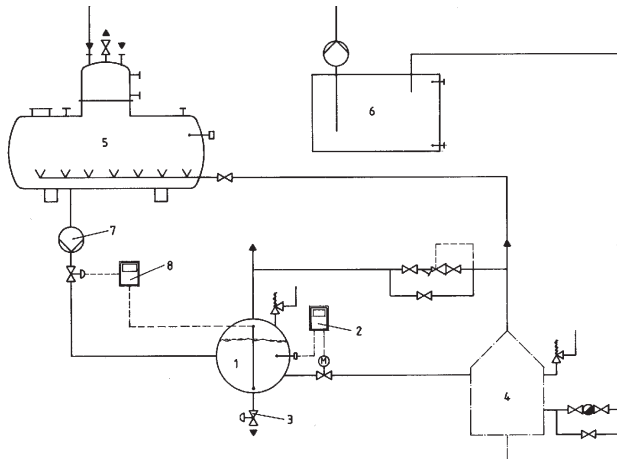

- 1) Boiler
- 2) Continuous blowdown
- 3) Bottom blowdown
- 4) Blowdown flash vessel
- 5) Feedwater tank with deaerator
- 6) Blowdown receiver
- 7) Feedwater pump
- 8) Feedwater level control

System Operation & Installation

Boiler blowdown is controlled by monitoring the unneutralized conductivity of the boiler water. Boiler. Directly related to the conductivity level is the level of total dissolved solids (TDS). This indicates the tendency of the water to form scale.

During boiler operation there is a constant discharge of blowdown allowing the electrode to sense the conductivity of the boiler water. When the conductivity exceeds the preset level, the blowdown valve is adjusted to allow a higher flowrate. Once the conductivity returns to the optimum level, the valve is re-adjusted to a position of low flowrate. Changes in boiler steam load or feedwater quality are quickly and accurately compensated for by the continuous monitoring of the conductivity.

When the boiler is shut down the continuous blowdown valve is closed. When first starting up the valve is completely open which then purges the system.

System Maintenance

The TDS Control System requires little servicing and in most cases yearly maintenance is simply a matter of carrying out normal inspection and

then cleaning the electrode tip.

6

Examples of installation

To reduce installation costs the system has a ragged design.

The electrode can be installed in 3 places:

- Directly into the boiler (Figure A)
- In a mounting flange in the continuous blowdown line (Figure B)
- In a pot in the continuous blowdown line (Figure C)

Thus all blowdown flows past the electrode and there is no waste. Furthermore, maximum heat recovery is possible. There is no need for sample coolers or flow reduction orifices and the design remains compact and easy to service.

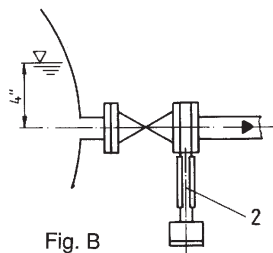

Fig. B

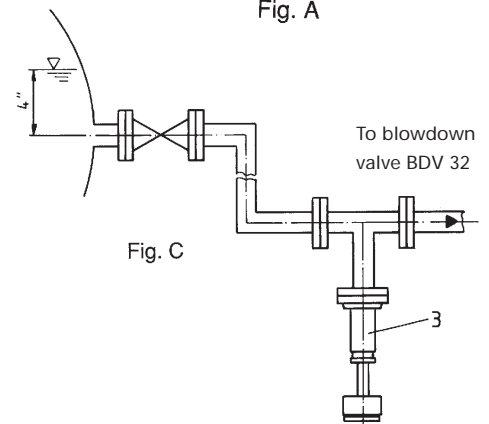

Fig. C

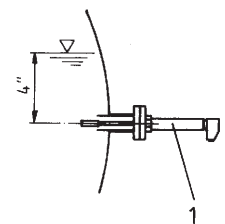

Fig. A

CEMF 100 / 600

WF 40 / 300

MP 100 / 600 + CEMF 100 / 600

Automatic continuous TDS control system

Conductivity sensing electrodes

Boiler water TDS is monitoring using electrical conductivity.

The actual boiler conditions are measured since sensing occurs at boiler pressure and temperature. We offer electrodes which are operating with a high-frequency, constant voltage AC Signal. This ensures accurate conductivity monitoring whilst also eliminating the deposition of solids on the measuring surface. The stainless steel electrode top with PTFE insulation is robust and thus needs little servicing.

CET 32 / 238

Conductivity electrode with threaded ($1/2''$) connection. Sensing element length of 47 mm ($1 7/8''$) with PTFE insulator and austenitic stainless steel tip. Die-cast aluminium terminal box with $1 7/8''$ conduit hole and polyurethane coating for NEMA 4X service (VDE). Maximum pressure of 32 barg (465 psig) at 238 °C (460 °F).



CET 32/238

CEMF 100 / 600

Conductivity electrode with flanged connection (2" ANSI PN 100 600 RF) for installation into mounting pot, MP 100 / 600. Sensing element length of $10 5/8''$ (270 mm) with stainless steel jacket surrounding PTFE insulator and austenitic stainless steel core. Die-cast aluminium terminal box with $1 7/8''$ conduit hole and polyurethane coating for NEMA 4X VDE service. Maximum pressure of 48 barg (700 psig) at 265° C (509 °F).



CEMF 100/600

MP 100 / 600

Carbon steel mounting pot with straight through configuration for installing CEMF 100 / 600 in continuous blowdown line. Available with 1- or 2- inch ANSI 600 (PN 100) RF flanged connections.

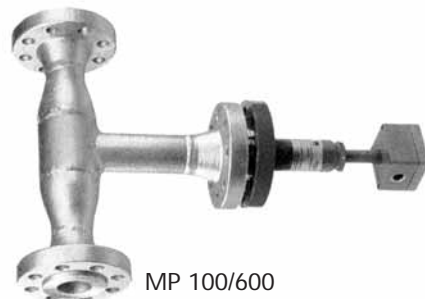

MP 100/600

WF 40 / 300

Forged steel wafer mounting flange for installing in CET 32 / 238 in continuous blowdown line. Sizes $3/4 - 1 1/2''$ for sandwiching between ANSI 300 RF PN 40 flanges.



WF 40/300

Automatic continuous TDS control system

Continuous blowdown valve

At the centre of our system is a control valve, a rugged valve which is virtually maintenance-free.

The design of the valve, plug and seat (Titanium Alloy) reduces wear and tear on the valve and seat.

The calibrated scale plate can be easily used to set the continuous blowdown valve precisely for any flowrate.

Using the cams in the electric actuator the desired settings are achieved. A low-speed, high-torque actuator ensures reliable and trouble-free operation. Manual control is also possible by declutching the machine.

Valve sizes range from $\frac{3}{4}$ " to 2" and have flanged connections.

Models suit boilers up to 40 barg (582 psig) and blowdown capacities from 20 kg / hr to 20.000 kg / hr, 50 to over 50.000 lb / hr.



Blowdown valve BDV 32

Conductivity control unit

- Continuous provision of LED-indicated boiler water conductivity allowing easy visual monitoring.
- 0 – 10000 ppm range with linear scale suitable for almost all boilers.
- Reliable relay output for three-position valve control
- Continuous 0 – 20 mA (4 – 20 mA) current output to remote display alarms or input to energy management systems.
- Four-core shielded cable to electrode giving accurate conductivity measurement and preventing interference.
- Accurate maintaining of required blowdown rate $\pm 5\%$.
- Controller set point and display calibrated in ppm for easy use.
- Easy calibration adjustment to compensate for different pressures and waters in the boiler.
- Control unit completely prewired and tested ensuring easy installation.
- Control unit for each boiler for continuous monitoring ensuring easy isolation during boiler maintenance.
- main supply required 230 or 110 V, 50 or 60 Hz.

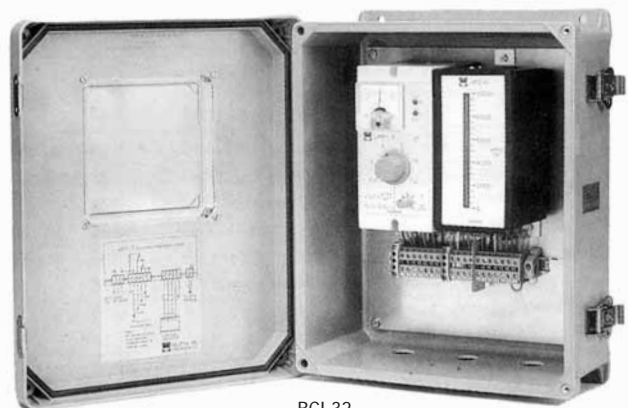

BCI 32

Automatic intermittent bottom blowdown

A programme-controlled unit together with a rapid-action intermittent blowdown valve from the system of automatic intermittent bottom blowdown. This system makes sure that all precipitated solids and sludge left behind after continuous blowdown are removed from the boiler.

The programme-controlled blowdown system is made up of an electronic cycling timer, a three-way solenoid valve and a strainer. A range of between 0,5 and 30 hours is offered by the cycling timer for the blowdown interval. The duration of this operation can be adjusted within a range of 1 to 60 seconds (optimum valve = 2 s). The timer incorporates a manual push-button override which is used for testing or also for manual blowdown.

The rapid action blowdown valves make use of a diaphragm actuator compressed air operated.

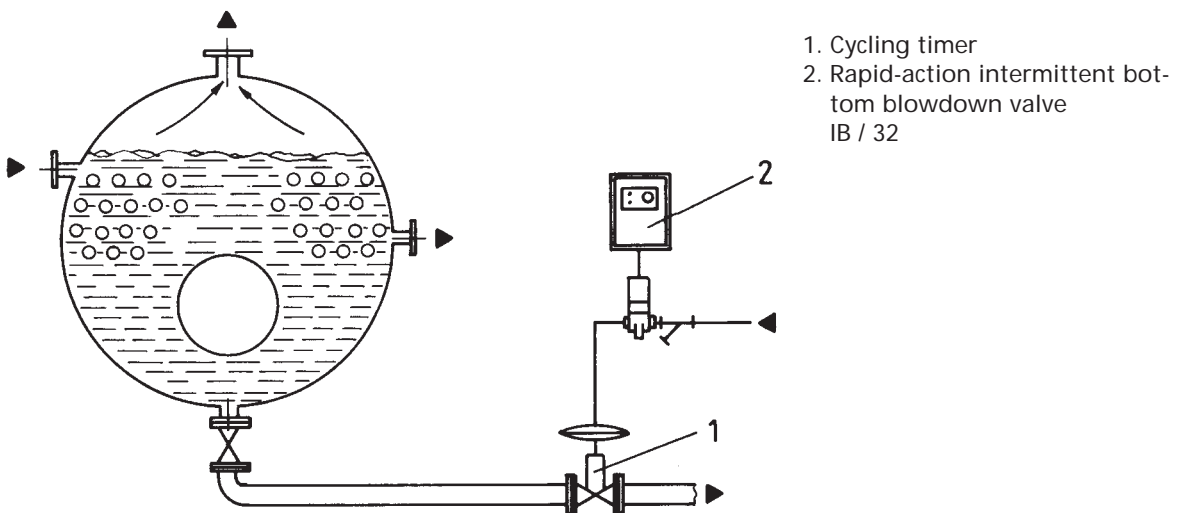

Quick Closing Valve

| Size | mm | 15 | 20 | 25 | 32 | 40 | 50 |
|--------------------------|--------|-----|-----|-----|-----|-----|-----|
| face to face globe type | mm | 130 | 150 | 160 | 180 | 200 | 230 |
| face to face angle type | mm | 90 | 95 | 100 | 105 | 115 | 125 |
| center to top globe type | ca. mm | 230 | 230 | 230 | 240 | 250 | 250 |
| center to top angle type | ca. mm | 220 | 220 | 230 | 240 | 230 | 240 |
| flange dia | mm | 95 | 105 | 115 | 140 | 150 | 165 |
| hole dia | mm | 65 | 75 | 85 | 100 | 110 | 125 |
| No. of holes | mm | 4 | 4 | 4 | 4 | 4 | 4 |
| hole Ø | mm | 14 | 14 | 14 | 18 | 18 | 18 |

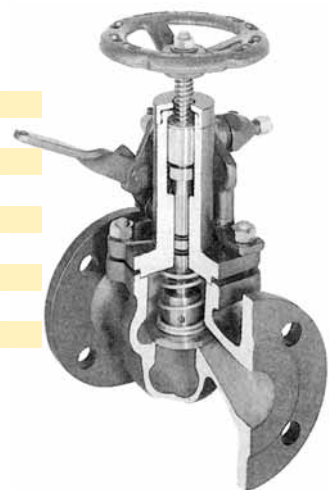

VN - Pumpen

Valves, Instruments, Supervision

Automatic continuous feedwater control

Modulating control with high-level alarm and first low-level alarm

The modulating controller consists of the level probe Type LE / C – 800 and the level controller Type CLC – 32.

The adjusted set point in the controller compares the controlled variable which is directly proportional to the water level. The water level is measured by the level probe. The positioning signal for the electric control valve, which changes the feedwater flowrate, is given by the difference between the two afore-mentioned values. The proportional controller is installed with a manual control station, contacts which signals high level and first low-level and a current output to the level indicator (Type LI / 32) which in turn indicates the water level.

The switch points can be adjusted at any stage and within the whole measuring range.

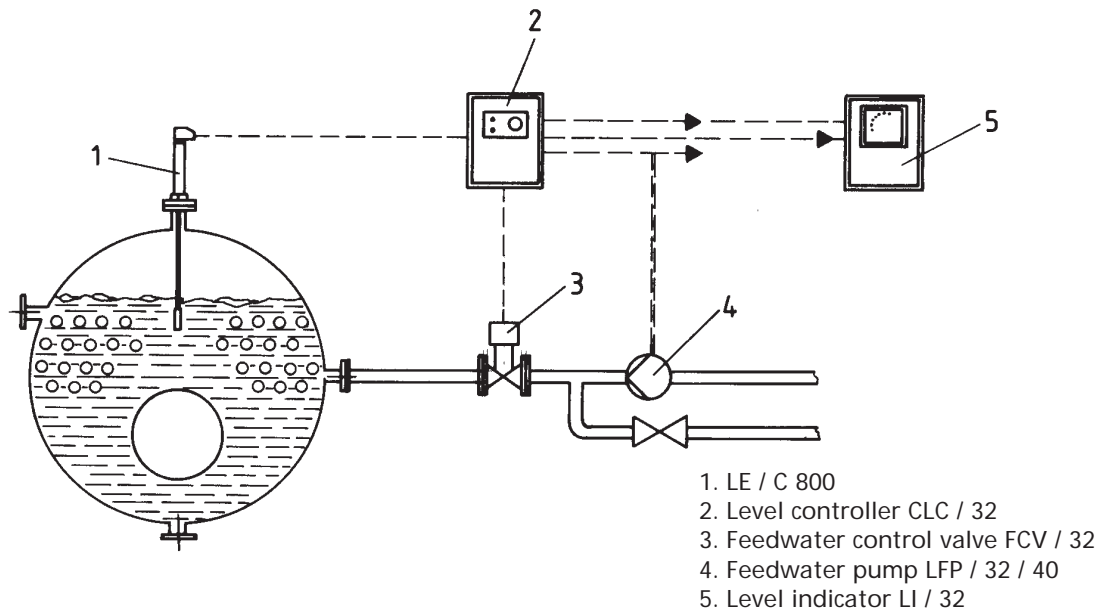

6



Technical data

| | |
|---------------------|---|
| Type | Control valve series FCV 16-40 |
| Nominal diameters | DN 15 – 150 |
| Pressure ranges | PN 16, 25, 40 |
| Body materials | GG-25, GGG-40.3, GS-C 25 N other materials on request |
| Plug design | Parabolic plug |
| Guidance | Plug shaft guided |
| Flow characteristic | Option: linear or equal percentage |
| Positioning ratio | 50:1 |



Temperature regulator

Application and instrumentation:

Temperature regulators without auxiliary energy are control devices for which the temperature of the medium supplies the energy that is needed to operate the regulating valve. These devices are suitable for heating- and cooling systems of industrial-, municipal- and domestic plants, for instance heating, air-conditioning and ventilating plants, cooling of engines, condensate and sewage plants, steam- and heat generators, heat exchanger, boiler, storage tanks, natural gas and heavy fuel oil-plants, drying rooms and chambers, greenhouses and extended pipe systems.

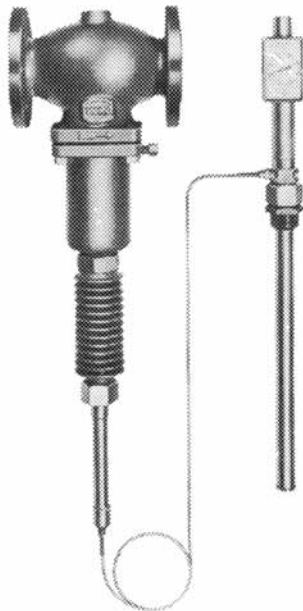

Design:

with 2-way or 3-way regulating valve (also balanced) for heat carrier as water, oil and all non-aggressive agents.

Materials:

brass, cast iron, spheroidal cast iron, steel

Connections:

DN 15 – DN 250

Operating temperature:

up to 350 °C

Steam trap



thermostatic with stainless steel (bimetallic) regulator



thermostatic with membrane regulator

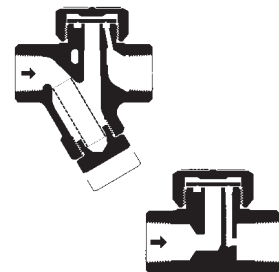

thermodynamic

VN - Pumpen

Valves, Instruments, Supervision

Automatic control armatures

2/2 Directional solenoid valve



Materials: brass, stainless steel, delrin, cast iron, brass nickel coated, steel browned, viton, PTFE, NBR

Connections: 1/8" – DN 150

Operating pressures: PN 10, PN 16, PN 25, PN 40

Voltage: AC = 24, 42, 110, 220 V, 50 Hz,
60 HzDC 0 12, 24, 110, 196 V –

medium supplied or direct activated, also explosion-proof design.



Plunger valves, separate excited

pneumatic-, hydraulic- or self-medium activated seat valves. 2/2 and 3/2-way design suitable for chemically neutral and aggressive agents



Materials: brass, bronze, cast iron, steel, stainless steel, NBR, EPDM, FKM, PTFE, special materials

Connections: DN 2 – DN 250

Operating pressures: PN 0 – PN 100 and vacuum

Options: - spring reset
- diaphragm or piston operated
- safety switch

Motor valves

piston-, diaphragm-, hose-, slide valve activated by electric motor, shut-off valve or regulating valve, 2/2-way- and 3/2-way design, suitable for neutral, aggressive, gaseous and liquid agents, with or without safety switch



Materials: brass, bronze, cast iron, spheroidal cast iron, steel, stainless steel, NBR, FKM, PTFE and special materials

Connections: DN 1 – DN 400

Operating pressure: PN 0 – PN 160

Level switches

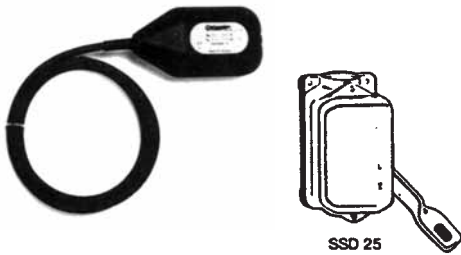

Float switch (ball switch)
with impact resistant casing made of non-conductive material, standard cable length, 3 m (longer cable available), suitable for liquids up to 60 °C, contactrating up to 1,1 kw at 230 V AC with 1-pole connection in combination with contactor suitable for every motor power

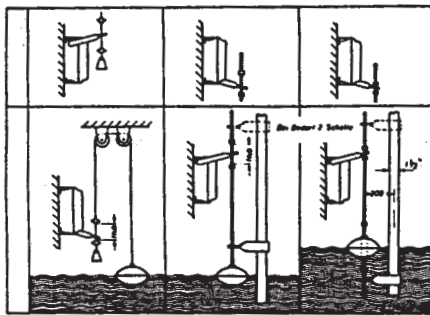

Float switch,
3-poles, 400 V, 25 Amp.
with rope or rods,
float made of copper or polyethylene, casing made of non-conductive material or cast iron (also explosion-proof designs)

Float switch, magnetic
for lateral mounting, flanged or threaded

Materials: Polypropylene, PVDF, PTFE, stainless steel, hastelloy C
function of switch: opening contact, closing contact, make-and-break contact (also explosion-proof designs)
operating temperature: up to 250 °C

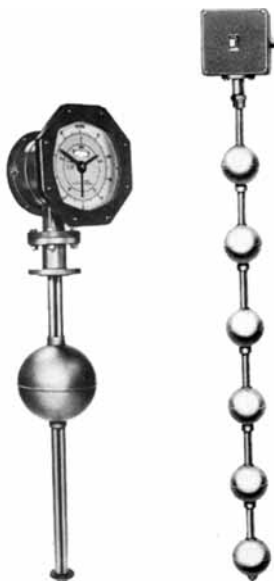
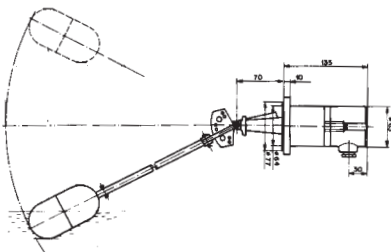

Immersion probe
controller operated by magnets for the automatic regulation of liquid levels.

Materials: brass, stainless steel, copper, polypropylene, PVC, perlon, PVDF and titanium
function of switch: opening contact, closing contact, make-and-break contact
number of contact: up to 10
operating temperature: up to 200 °C
operating pressure: PN 10, special designs are possible

Also as level gauge with direct analogue indication and for transmitter.

VN - Pumpen

Valves, Instruments, Supervision

Pressure gauges and controllers

Pressure gauges

Models: bourdon-, diaphragm- and spring pressure gauges
Diameter: 40, 50, 63, 80, 100, 160, 250 mm
Quality classes: 0,1; 0,2; 0,3; 0,6; 1,0; 1,6; 2,5
Measuring range: 0 – 1600 bar
Options: stainless steel casing
sensitive pressure gauge
glycerine filling
transmitter



Models with electrical contact switch:

function of switch: opening contact
closing contact
make-and-break contact
(also explosion proof designs)
switching points: fix point (gauged) or variable min./max.
contact: reed switch, micro switch, inductive contact switch

Pressure transducers, threaded
transmitter built-in or separate,
explosion-proof design, digital indicators
differential pressure transmitter



Switching equipment

Pressure switch

casing made of non-conductive material, protection class IP 54,
3-poles, 400 V up to motor power of 2,2 kw, with 1-pole connection in combination with contactor suitable for every motor power
min. starting pressure: 0,3 bar
max. opening pressure: 22 bar

Precision pressure switch

casing made of non-conductive material, with micro-switch, protection class IP 54, 1-pole connection for control circuit in combination with contactor suitable for every motor power.
min. starting pressure: 0,07 bar
max. opening pressure: 24 bar



Thermometers and Controllers



Industrial glass thermometers / shaft thermometers / dial thermometers

Measuring systems: bimetal, liquid filled or gas filled (with fixed shaft or capillary)

Diameter of casing: from 34 mm up to 250 mm

Quality classes: 0,6; 1,0; 1,5; 2,0

Measuring range: from - 250 up to + 650 °C



Designs with electrical contact switch:

Function of switch: opening contact
closing contact
make-and-break contact
(also explosion proof designs)

Switching points: fix point (gauged) or variable min./max.

Contact: reed switch, micro switch, inductive contact switch



Panel mounted thermometers
(LED or LCD-display)

Hand-held thermometers
digital or analogue display, (also explosion proof design)



Transducers
thermo-couples, resistance thermometer

Transmitter
suitable for a.m. transducers,
also temperature differential measurement
and calorimetry in combination with flow
measurement



VN - Pumpen

Valves, Instruments, Supervision

Flow measuring



All meters can be provided with impulse transmitter for remote data processing, control of semi- or fully-automatic dosing- and filling procedures and also several regulation tasks in process- and industrial engineering.

Water meter

Impeller type meter



- Connections: DN 15 (1/2") – DN 50 (2")
- Measuring range: 0,1 m³/h – 30 m³/h
- Pressure ratings: PN 16, PN 25, PN 40 (higher pressure ratings are available)
- Operating temperatures: up to 180 °C
- Accuracy: ± 2 %
- Mounting position: horizontal or vertical

Meters for aggressive medium are available in special design. Meters with dosing scales for manual or semi-automatic operation (with mounted solenoid valves) are available.

6



Large water volume meter (Woltman-meter)

- Connections: DN 50 – DN 500
- Measuring range: 1,5 m³/h – 4500 m³/h
- Pressure ratings: PN 16, PN 25, PN 40 (higher pressure ratings are available)
- Operating temperatures: up to 200° C
- Accuracy: ± 2 %
- Mounting position: horizontal or vertical

Meters for aggressive medium are available in special design. Meters with dosing scales for manual or semi-automatic operation (with mounted solenoid valves) are available.

Flow measuring



Positive displacement meter
Rotary-piston meter

Vane meter

Oval gear meter

Mutating disc meter

Screw type volume meter



Connections: DN 4 – DN 400 mm

Measuring range: 1 l/h – 2000 m³/h

Operating

temperatures: up to 300 °C

Operating pressures: up to PN 100

Accuracy of

measurement: ± 0,2 % (gauged) - ± 1 %

Materials: brass, bronze, cast iron, spheroidal cast iron, aluminium, steel, stainless steel, plastic (PVC, PP, PTFE, PVDF)

Application fields: mineral oils, laquer, paints, dispersions, adhesive materials, fats, molasses, solvents, gums, alcohols, bitumen, acids, brines, juices and many other liquids.



Magnetic inductive flow meter:

(without any moving parts and without any restriction of the pipe section)

Connections: DN 2 mm – DN 3000

Measuring range: 0 - 100000 m³/h

Operating

temperatures: up to 250 °C

Operating

pressures: up to 250 bar

Accuracy of

measurement: ± 0,3 % - ± 3 %

Min. conductivity

of the medium: 0,5 micro S/cm

Materials: steel, stainless steel, hard rubber, PTFE; PP, hastelloy

Application fields: water, sludges, molasses, paste and many other mediums



VN - Pumpen

Valves, Instruments, Supervision

Flow measuring

Mass-flowmeter



acc. to coriolis principle

Connections: DN 15 – DN 250
Operating temperatures: up to 220 °C
Operating pressures: up to PN 64
Accuracy of measurement: $\pm 0,3 \% - \pm 1 \%$
Materials: stainless steel, hasteloy, Halar coated
Application: fats, oils, bitumen etc. (especially for electric non-conducting medium)

Flow meter floating body



Connections: DN 8 – DN 300
Measuring range: 0,0001 m³/h – 200 m³/h
Operating temperatures: up to 350 °C
Operating pressures: up to 100 bar
Accuracy of measurement: $\pm 0,5 \% - \pm 3 \%$
Materials: cast iron, steel, stainless steel, PVC, PTFE, PVDF, glass
Application: liquids and gases



Flow measuring

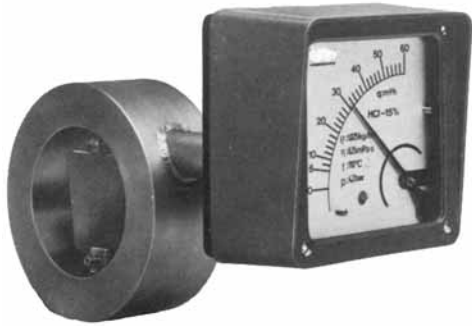

Flow indicator with measuring flap:

Connections: DN 15 – DN 400

Measuring range: 0,15 m³/h – 700 m³/h

Operating temperatures: up to 250 °C

Operating pressures: up to 25 bar

Accuracy of measurement: ± 5 %

Materials: cast iron, cast steel, stainless steel, cast bronze, glass



Flow switch

Designs forms: paddle switch, control piston switch, float switch, measuring orifice switch, electronic flap switch

Sizes: 1/4" – DN 600

Connections: flanged or screwed connections

Operating temperatures: up to 350 °C

Operating pressures: up to 200 bar

Materials: brass, cast iron, steel, bronze, stainless steel, PVC, PVDF, PP

Switching points: fix point (gauged) or variable min. / max.

Contact: reed switch, micro switch, mercury switch, inductive contact switch

Application: liquids (for example dry running protection for the pumps) or gases.

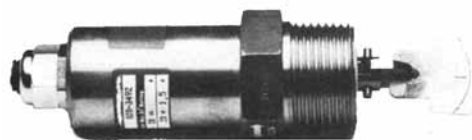

Computing – and monitoring instruments

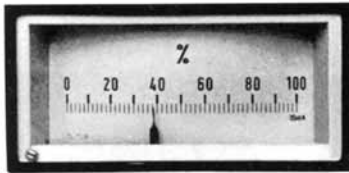

Indicators

Quadratic or rectangular for panel mounting, pointer or LCD-display

Object of measurement: current, voltage, frequency, limit switches possible



Application:

indication of instantaneous flow l/h, m³/h, gpm etc. with suitable transducer



Printer-recorder

Counting or analogue printer
dot or line recorder

Up to 6 input channels

Panel mounting, wall mounting
or desk-casing



Regulator

two-therm- and three-therm grade regulator,
continuous controller

Options:

set point adjustment digital or analogue,
external or manual, digital display for actual
value, data code crossover

Computing and monitoring instruments



**Pulsecounter –
Batch counter**

- electromechanical or electronic (with LCD-display)
- 4, 6 or 8 decades
- with/without zero-reset (electrical or manual)
- panel mounting or separate casing
- various supply voltages or battery operation
- also for hazardous areas



Application:
remote totalisation.
Dosing, batching and mixing of liquids.

**Batchin units –
Flow computer**

electromechanical or electronic panel mounting or wall mounting

Application:
controlling of dosing- and racking processes

Options:

- instantaneous flow indication in l/h, gpm etc. ,
- max. and min. signals for min. and max. flow,
- analogue signal 0/4 – 20 m A/O – 10 V,
- data code crossover,
- frequency output,
- differential measurement (forward-return pipe),
- temperature compensation

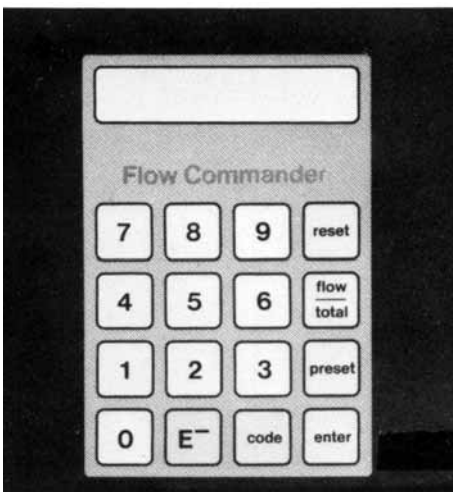

VN - Pumpen

Valves, Instruments, Supervision

Supervision instruments for diesel engines

Temperature: (for cooling water or oil)



Transmitter, 6 - 24 Volt
1-pole 2-pole



Indication



Alarm

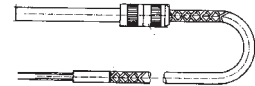

Transmitter
acc. to the rules of
ship-classifications



Transmitter, 6 - 24 Volt
1-pole 2-pole



Pressure: (for oil)



Indication



acc. to the rules of
ship-classifications



Speed sensor

Speed:



Frequency-voltage converters
with built-in speed controller



Indicator
DIN 5375

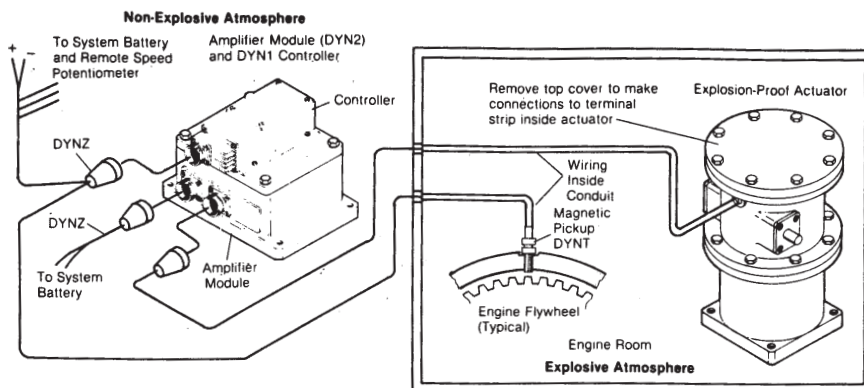

Barber Colman controller for exating requirements of constant speed delivery