

Low pressure centrifugal pump / process pump acc. to DIN 24255



Application:

Water supply for communities, industrial works and agriculture fields, for irrigation and drainage, seawater circulation, brine pumping, condensate transfer, hot water, cooling water, oil circulation, mixing and loading pump.
Handling of clean or turbid, non-aggressive liquids which do not contain any solid constituents.

Design:

Horizontal, single stage, single flow centrifugal pump in back pull-out design; process pump acc. to DIN 24255 (the pump is available also with pillow block)

Connections:

suction socket axial
discharge socket vertical upwards
flanges acc. to DIN PN 10

Temperature:

normal from - 30° C up to + 120 °C
(higher temperatures are possible)

Materials:

casing and impeller: cast iron or bronze
shaft: steel or chrome steel
wearing ring: cast iron or bronze
shaft sleeve: stainless steel or bronze

Capacity range:

5 – 500 m³/h
(special sizes up to 2000 m³/h)

Pump pressure:

max. 95 m

Shaft sealing:

stuffing box (also cooled), mechanical seal

Driver:

electric motor or gasoline/diesel engine

Direction of rotation:

cw

Power transmission:

flexible coupling or spacer coupling. V-belt drive is also possible.

Bearing:

on drive side, double ball bearings grease lubricated

VN - Pumpen

Pumps

Further versions for low pressure centrifugal pumps acc. to DIN 24255 & bloc-pumps (closed-coupled centrifugal electro pumps)

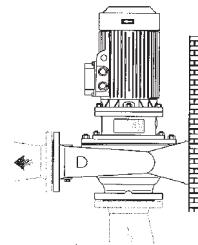
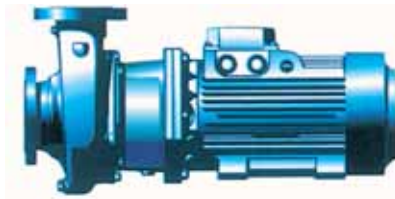
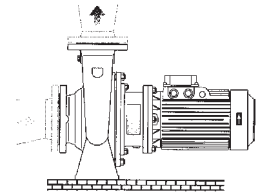
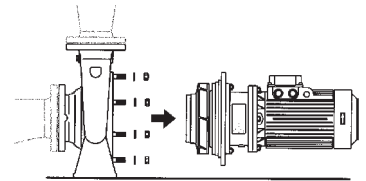

4

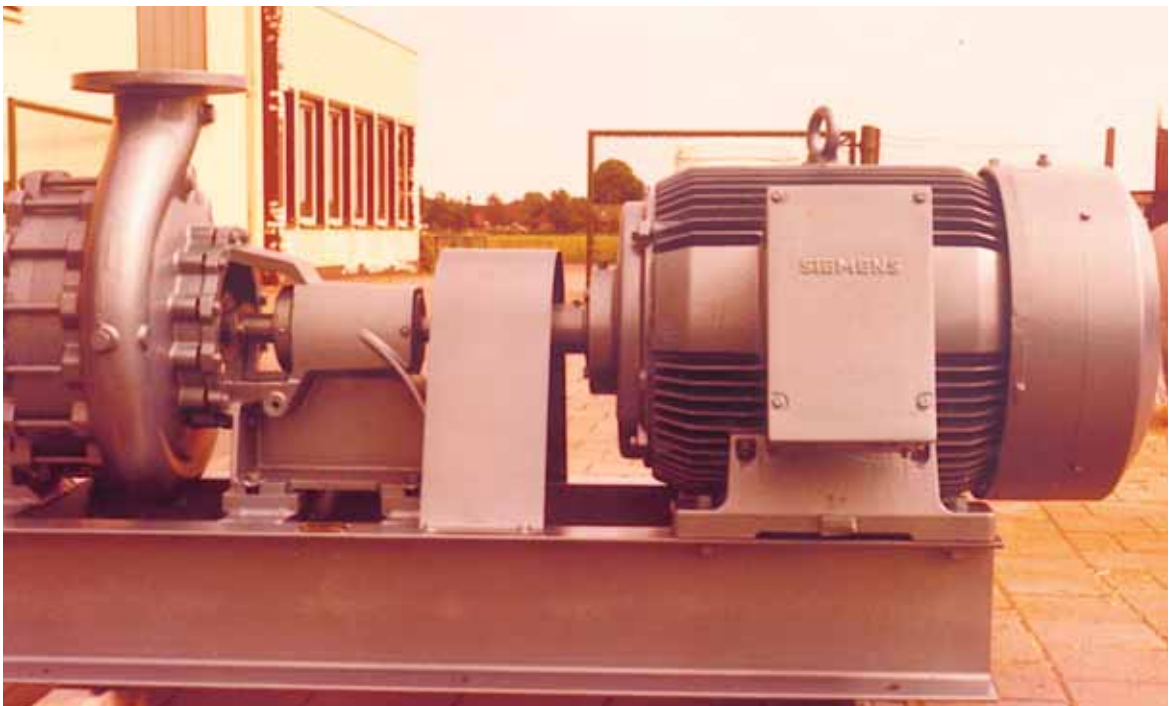

Special big sizes: for higher head with two stages

2

Vertical centrifugal pumps, pump-casing acc. to DIN 24255 for tank-installation

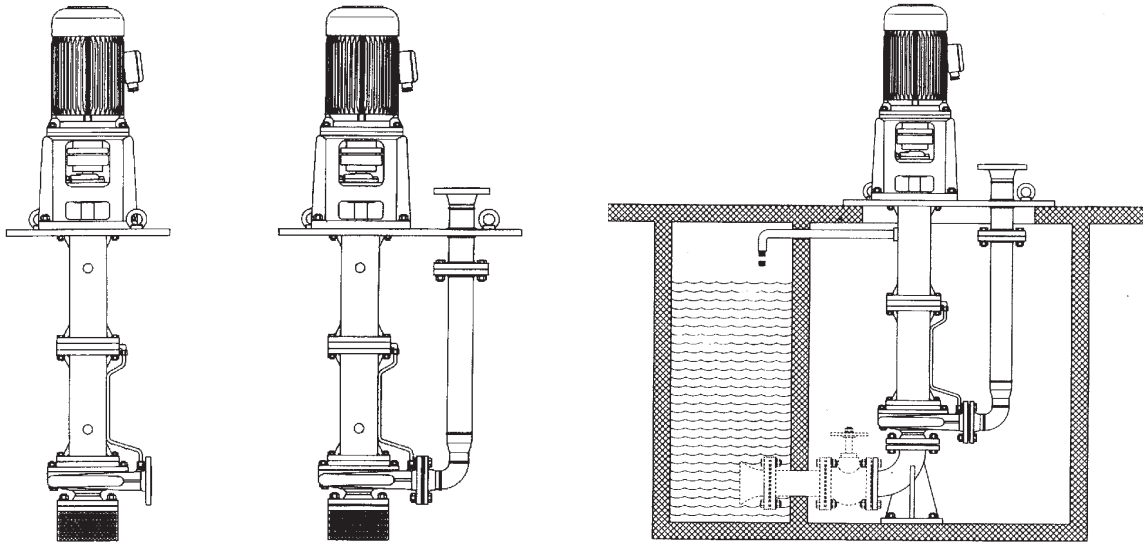

Pumps are vertical line-shaft, single stage pumps with base plate. The main components (casing, cover, pump flanges, etc.) are DIN-24255 Standard based.

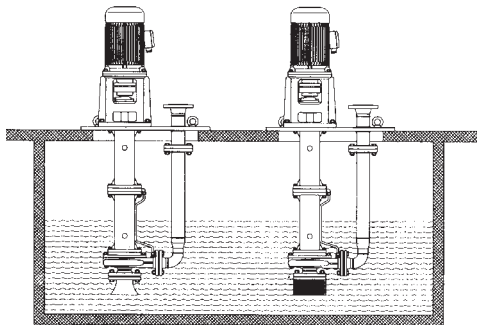

Pumps may pump a wide range of fluids, such as

- | | |
|----------------------------|------------------------|
| Turbine lubrication oil | Antifreeze products |
| Cutting oils | Dips |
| Drilling oils | Galvanic baths |
| Hardening oils | Methyl chloride |
| Capacitor oil | Condensates |
| Residual oils | Detergents |
| Ethyl-acetate | Solvents |
| Sulphuric acid | Phenols |
| Acrylonitriles | Phosphates |
| Sugar water | Calcium hydroxide |
| Water with sand | Zinc-phosphate sludges |
| Water with millscale | Methacrylates |
| Water with corundum powder | Paints: |
| Water with emery powder | Cataphoresis paint |
| Water with coke wastes | Phosphate paints |
| Water with silicates | Degreasing paint |
| Sea water | Water with pigments |
| Cooling water | Ultrafiltrates |
| Dyeing water with fibers | Paint sludges |
| Demineralized water | Chromic acid wastes |
| Water from strip rollings | Kerosenes |
| Warm water | Soda recovery |
| Water with ashes | Dreasing solutions |
| Water with paint | Drilling oils |
| Draining water | Tri-ethylen-glycol... |

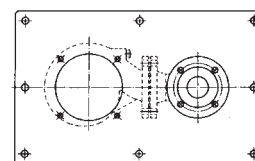
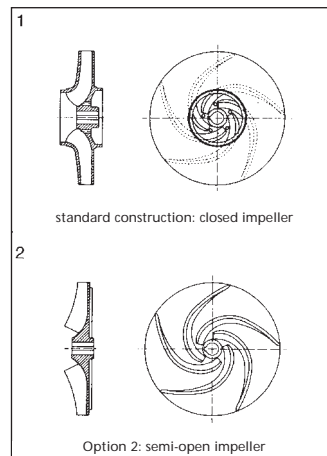

Standard construction:
rectangular base plate

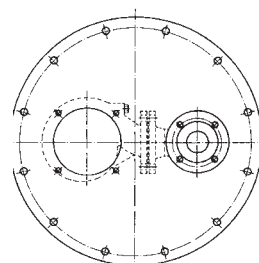

Special circular base plate

Chemical standard pump

acc. to DIN 24256



Application: Chemical industry, food industry, water treatment and manufacture of apparatus. Applicable for any kinds of liquid which do not tend to crystallize and do not contain a very low percentage of solids. The material combinations are selected under these aspects.

Design: Horizontal, single stage, single flow volute casing centrifugal pump in back pull-out design. Process pump acc. to DIN 24256. The closed impeller is provided with double curved blades. The hydraulic layout of the pump is carried out acc. to DIN 24256.

Connections: suction socket axial
discharge socket radial upwards
flanges acc. to DIN PN 10 or 16
(British standard or ANSI possible)

Temperature: from -40° up to +200 °C

Capacity range: 5-500 m³/h (special sizes: up to 2000 m³/h)

Delivery head: up to 160m

Shaft sealing: cooled or uncooled stuffing box or mechanical seal

Driver: electric motor, building form B3

Direction of rotation: cw

Power transmission: flexible coupling or spacer coupling, V-belt drive is also possible

Bearing: on drive-side double ball bearings
grease or oil lubricated

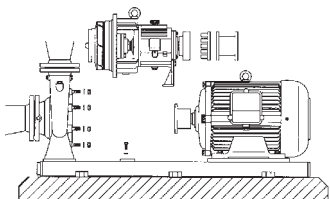
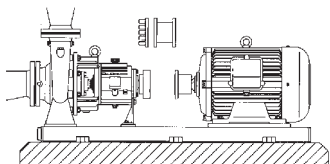
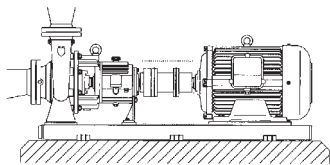

Materials: casing, impeller, and wearing ring: cast iron, spheroidal graphite iron, cast steel, bronze, stainless steel, titanium or different kinds of plastic materials

shaft: chrome steel, chrome nickel steel,

shaft sleeve: selected in accordance with shaft and sealing

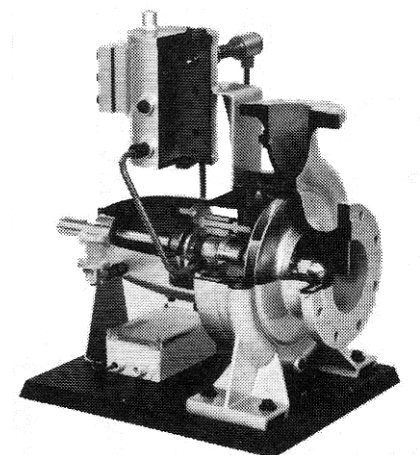

Chemical standard pump

acc. to DIN 24256

Details of some options

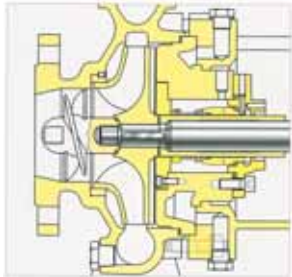

Pumps with includer

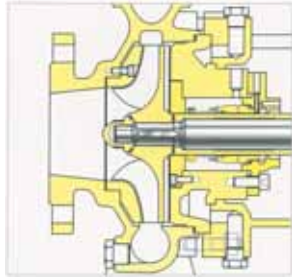

Pumps with semi-open impeller

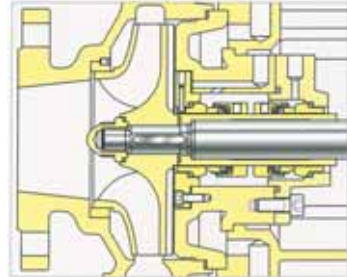

"Back to back" mech. seal and cylindrical channel

Some examples for special executions:

Exhaust gas boiler circulation pump with mechanical seal up to 185 °C without external cooling



Design acc. to API 610 , latest edition horizontal in centre line arrangement



Vertical inline



Vertical wet installation



Thermal oil circulating pump



Application: In thermal oil heat transfer plants (acc. to DIN 4754) for circulating thermal oils with saturation pressure ≤ 1 bar. Thermal oils clean, non-aggressive, which do not contain any solid constituents.

Thermal oil pumps are used mainly in chemical industry, rubber- and plastic industry, food industry, paper mills and industrial laundry plants. The pump is specially designed for the pumping of thermal oils.

Design: Horizontal, single stage, single flow centrifugal pump. Main dimensions and hydraulic outputs correspond to DIN 24255. Thermal oil heat, which is transferred to casing parts and pump shaft is reduced by dissipation of heat, so that the pump sealings and bearings are not affected by the high thermal oil temperature. This is achieved by a proper design of pump casing, cover and the bearing housing.

Connections:	suction socket	axial
	discharge socket	radial upwards
	flanges acc. to DIN	
Temperature:	max. 340 °C without cooling	
Pump pressure:	max. inlet pressure (system pressure)	5 bar
	max. pump pressure	25 bar
Shaft sealing:	mechanical seal with premounted stuffing box	
Materials:	casing: cast iron, spheroidal graphite iron or cast steel	
	impeller: cast iron	
	shaft: chrome steel	
Driver:	electric motor building form B3	
Direction of rotation:	cw	
Power transmission:	flexible coupling or spacer coupling	
Bearing:	ball bearings	

Glandless centrifugal pump in acc. to DIN 24256 with permanent magnetic drive arrangement

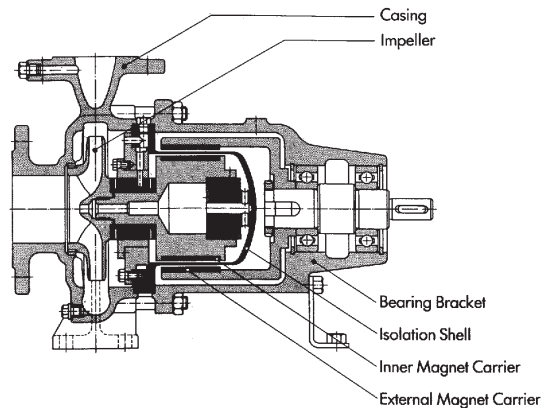
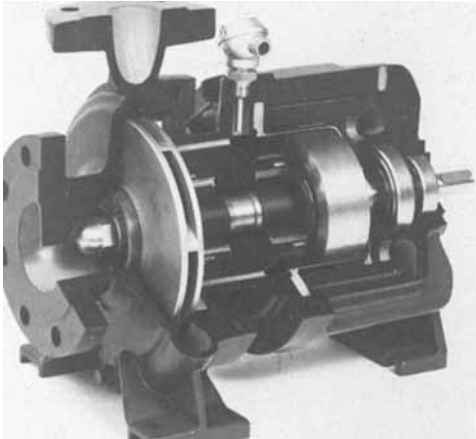

Application: chemical and petrochemical industry, ideally suited to applications where the prevention of seal leakage is a requirement and particularly with volatile, high-tempered, hazardous or toxic liquids.

Design: horizontal, single stage, single flow volute casing centrifugal pump in back pull-out design. Process pump acc. to DIN 24256. The closed impeller is provided with double curved blades. The hydraulic lay-out of the pump is carried out acc. to DIN 24256. The torque required to operate the pump is transmitted via a flexible coupling to the drive shaft which is supported in maintenance-free ball bearings. The drive shaft in turn has attached to it the external magnet carrier which is fitted with permanent magnets. An isolation shell separates the liquid chamber from the atmosphere. An inner magnet carrier (fitted with permanent magnets) is located inside the isolation shell and supported in sleeve bearings which are lubricated by the pumpage. The inner magnet carrier transmits the motor torque, at synchronous speed, to the impeller which is attached to it. The pump casing ensures a perfectly sealed unit.

Connections: suction socket axial
discharge socket radial upwards
flanges acc. to DIN PN 10 or 16
(British standard or ANSI possible)

Temperatures: from -120 °C up to +450 °C

Capacity range: up to 1000 m³/h

Delivery head: up to 150 m

Materials: casing and impeller: spheroidal graphite iron, cast steel, many kinds
stainless steels and titan
Isolation shell: NiMo16Cr16Ti
permanent magnets: depending on temperature

Driver: electric motor, building form B 3

Direction of rotation: cw

Power transmission: flexible coupling or spacer coupling

Bearing: on drive-side double ball bearings, grease lubricated

Lubrication systems: due to the internal design of the liquid chamber a force-fed flushing arrangement is required to lubricate the sleeve bearings and cool the area between the inner magnet carrier and isolation shell; therefore available are

- internal lubrication
- internal filtered lubrication
- internal separate lubrication via pumping ring
- external lubrication

Axial split-case-centrifugal pump

- Application:** for handling of crude oil- and intermediate products of refineries, for cooling water and public water supply, pipelines, fuel oil bunkering, in chemical and petrochemical industry, in shipbuilding and power plants.
- Design:** horizontal or vertical, single- or two stage, non-self priming, axially-split, double-suction. Also available as API-execution.
- Connections:** in-line execution with flanges
- Temperatures:** max. 160 °C
- Capacity:** up to 30.000 m³/h
- Delivery head:** up to 250 m
- Sealing:** stuffing box or mechanical seal
- Materials:**
- casing: cast iron, spheroidal graphite iron, cast steel, bronze, stainless steel, alu-bronze
 - impeller: cast iron, bronze, alu-bronze, chrome steel, stainless steel
 - shaft: steel, chrome steel, stainless steel
 - sleeve: bronze, stainless steel
 - wearing rings: cast iron, bronze, chrome steel, stainless steel
- Driver:** electric motor, diesel engine, steam turbine
- Direction of rotation:** cw or ccw
- Power transmission:** flexible coupling
- Bearing:** grease lubricated ball bearings at both sides.

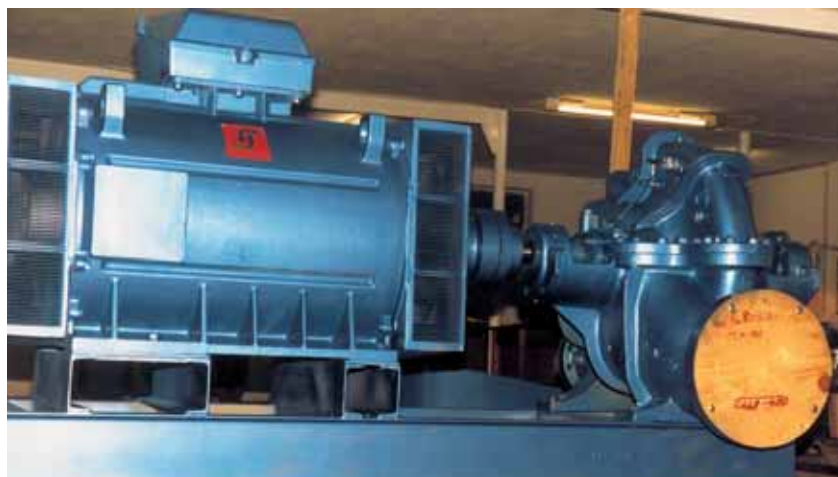
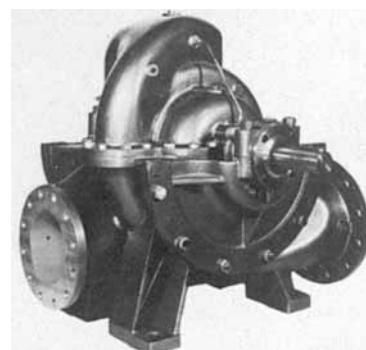
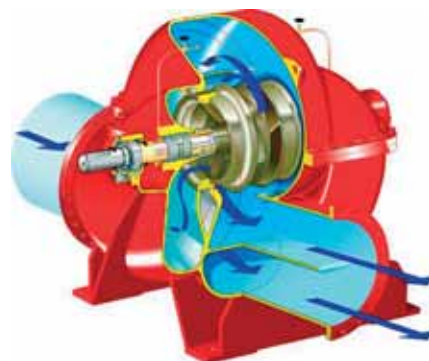

Axial split-case-centrifugal pump



4

Diesel engine driven axial split-case centrifugal pumps



9

High pressure multistage centrifugal pump

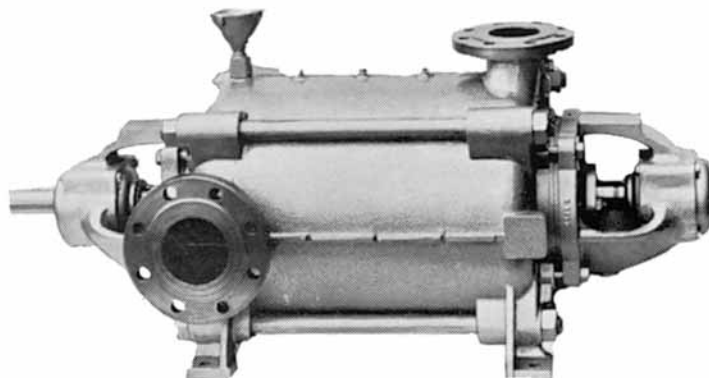

Application:

Community- and city water supply, cooling water supply, booster pump stations, irrigation systems. Shipbuilding industry: pump for bilge-, ballast- and fire extinguishing-service. High-pressure washing systems, air-conditioning and dust-arrester installation, chemical and petrochemical industry. For clean liquid chemical non-aggressive and free of mechanical solids.

Design:

Horizontal, high pressure, multi-stage centrifugal pump in robust, heavy duty design for continuous operation. Balancing of axial thrust is done by release borings (for higher pressure with relieving piston and also oppositely directed). Shaft sleeves in area of the stuffing boxes and wearing rings are replaceable. Stuffing boxes relieved from pressure. Vertical execution as described before but not available in all sizes and number of stages.

Additional equipments:

Built-in air-stage for self-priming execution and second shaft end.

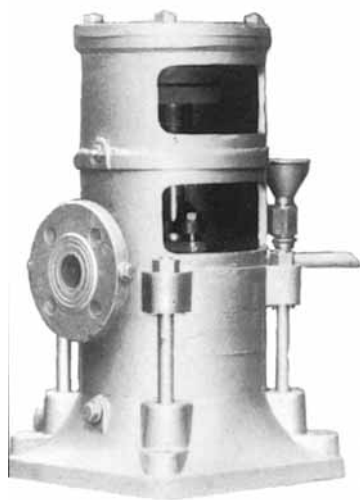

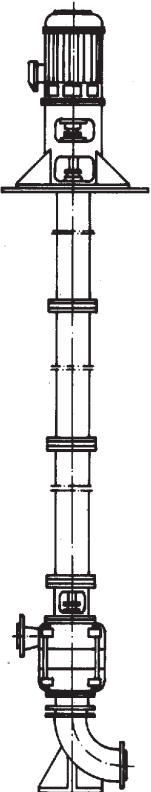
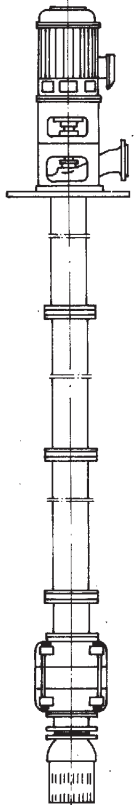

High pressure multistage centrifugal pump

Connections:	horizontal pump:	suction horizontal right, left or vertical upwards, discharge vertical upwards (special connections possible)
	vertical pump:	suction and discharge: 180° to each other on different level or on the same level (in-line). If required the discharge connection can be arranged 90° to the left or right of the suction connection.
Temperature:	up to 160° C, higher temperatures possible	
Capacity range:	1 – 1000 m³/h	
Delivery head:	up to 900 m	
Shaft sealing:	stuffing box or mechanical seal	
Materials:	casing:	cast iron, bronze, cast steel, stainless steel
	impeller:	cast iron, bronze, chrome steel, stainless steel
	wearing ring:	cast iron, bronze, stainless steel
	shaft sleeve:	bronze, stainless steel
	shaft:	steel, chrome steel, stainless steel
	air stage casing:	cast iron, bronze
	air stage impeller:	bronze
Driver:	electric motor or gasoline/diesel engine	
Direction of rotation:	cw or ccw	
Power transmission:	flexible coupling	
Bearing:	horizontal pump:	external grease lubricated antifriction bearings at both sides
	vertical pump:	grease lubricated ball bearing in motor-lantern, lower bearing as sleeve bearing liquid lubricated
Additional design forms:	Vertical pump with variable mounting length up to 10 m for wet and dry installation. Pumps according to API 610 and constructed as barrel pump.	

VN - Pumpen

Pumps

High pressure multistage centrifugal pump



Diesel engine driven axial split-case centrifugal pumps



Pump with heating coil and flame proof motor for refinery

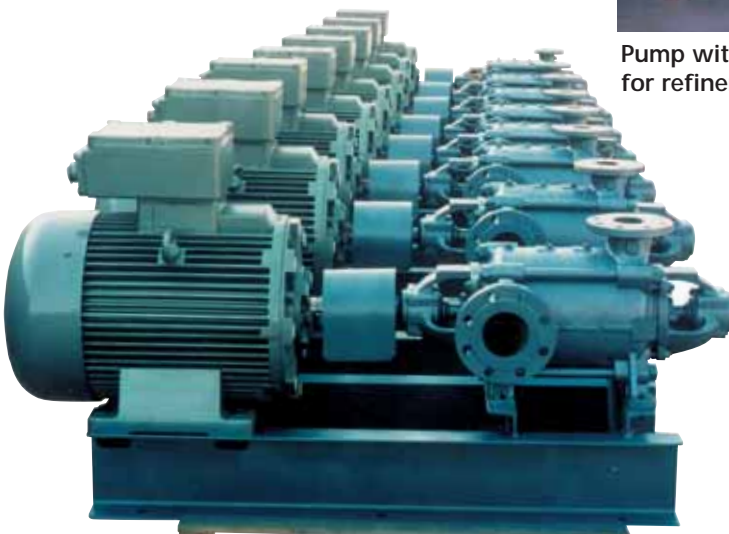

Pumps for ammonia with flame proof motors

Self-priming single- and multistage centrifugal pump with air stage



Application:

For the handling of fresh water, sea water, oils, brines, lyes, condensates etc. without any abrasive particles, and not chemically attacking the construction materials of the pump. In the shipbuilding industry as fire extinguishing-, bilge- and ballast pump. For irrigation, cooling-water circuits, water supply from own wells.

Design:

Single- or multi-stage centrifugal pump, radially split, horizontal. Conveying of gas by means of built-in priming impeller, or with integrated jet pump.

Connections:

suction socket: Upwards pointed. For priming operation it must be granted that the pump is filled with liquid.

discharge socket: upwards pointed

Temperature: -25 °C up to + 90 °C

Capacity: max. 500 m³/h

Delivery head: max. 200 m

Shaft sealing: stuffing box or mechanical seal

Materials:

casing: cast iron, bronze, bronze-plated
 impeller: cast iron, bronze
 air-impeller: bronze
 shaft: chrome steel, chromenickel steel

Driver: electric motor building form B3, or diesel engine

Power transmission: flexible coupling or V-belt

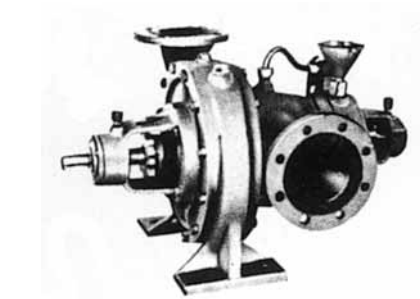

Side channel pump, self-priming

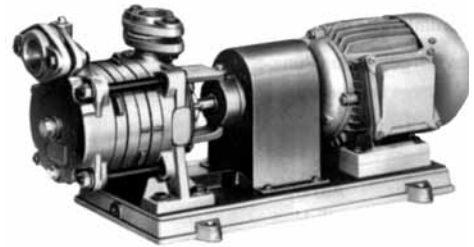
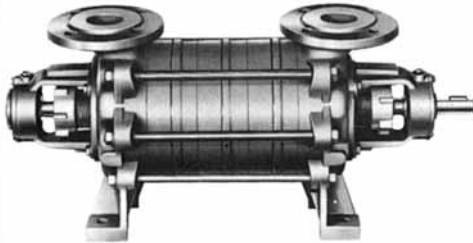

Application: water supply, hydrophore systems, irrigation plants, diesel-, gas- and fuel-oil supply as feed water pumps to boiler.

This pump can be used for the pumping of any kind of liquids, which are clean or turbid liquids without any abrasive matter.

The side channel centrifugal pump is a segmental type self-priming and handling gases during normal liquid duty, operating with unshrouded vane wheel impellers.

Normal design horizontal, some sizes are available in vertical design.

4

Connections:	suction and discharge connections upwards, with oval flanges including counter flanges or with round flanges without counter flanges.						
Temperature:	normal up to 120 °C, maximal 220 °C						
Pump pressure:	normal 10 bar, pressure ratings 16 bar up to 40 bar are available						
Capacity range:	0,1 – 40 m ³ /h						
Total head:	up to 300 m						
Shaft sealing:	stuffing box or mechanical seal						
Materials:	<table> <tr> <td>suction and discharge cover and intermediate pieces:</td> <td>cast iron, bronze, stainless steel</td> </tr> <tr> <td>impellers:</td> <td>special brass, bronze, stainless steel</td> </tr> <tr> <td>shaft:</td> <td>chrome-steel or stainless steel</td> </tr> </table>	suction and discharge cover and intermediate pieces:	cast iron, bronze, stainless steel	impellers:	special brass, bronze, stainless steel	shaft:	chrome-steel or stainless steel
suction and discharge cover and intermediate pieces:	cast iron, bronze, stainless steel						
impellers:	special brass, bronze, stainless steel						
shaft:	chrome-steel or stainless steel						
Driver:	electric motor or diesel/gasoline engine						
Direction of rotation:	cw, special design ccw						
Power transmission:	flexible coupling						
Bearing:	<p>on the discharge side: medium lubricated sleeve bearing on the suction side: grease lubricated ball bearings, or both sides with grease lubricated ball bearings.</p>						

Side channel condensate pump

Self-priming with NPSH inducer stage

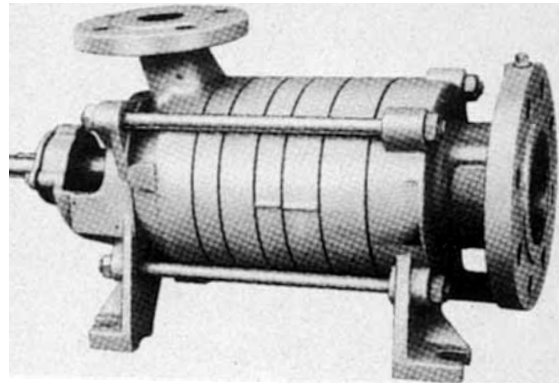
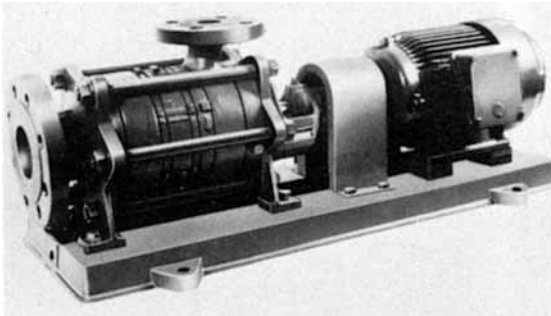

Application: condensate, distillate, refrigerants, boiler feed water and liquid gas pumping. This pump is also applicable at positive suction heads below 0,5 m.

This pump can be used for pumping any kind of liquids which do not tend to crystallize and do not contain any mechanical impurities, which can result in a wearing or a clogging effect.

Design: horizontal, self-priming side channel pump of segmental-type gas handling during normal duty – with open impellers and preconnected centrifugal stage in combination system for reaching of optimal NPSH values. The material designs which are available make possible an optimal rating corresponding to the required range of performance and the medium handled.

Connection: suction connection axial, discharge connection radial upwards flanged connections without counter flanges.

Temperature: max. 220 °C

Pump pressure: max. 40 bar

Capacity range: 0,1 – 36 m³/h

Total head: up to 300 m

Shaft sealing: stuffing box or mechanical sealing in all variations; (for example: internal sealing, external sealing, flushed, cooled, uncooled, balanced sealing arrangements)

Materials:

casing:	cast iron, bronze or stainless steel
vane wheel impeller and impeller:	special brass, bronze, stainless steel
shaft:	chrome-steel or stainless steel

Driver: electric motor, diesel engine

Direction of rotation: ccw

Power transmission: flexible coupling

Bearing: on the suction side – medium lubricated sleeve bearing
on the discharge side – grease lubricated ball bearing.

Self-priming centrifugal pump as bilge-, ballast- and fire extinguishing pump and for water containing sand and solids in suspension

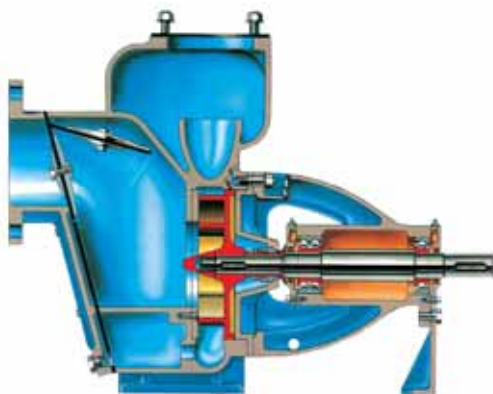

4

Application:

for handling liquids corrosive, aggressive with or without solids. The self-priming effect needs no extra device. Foot valve is not necessary.

Used as a bilge-, ballast- and fire fighting pump. Dewatering of construction pits draining, injection of well tubes, handling of dirty fuel.

Design:

the replaceable wear plate has an abrasion resistant facing and the open impeller has wide passages for handling solids. Many models have inspection-openings. Pump is only available in horizontal, single stage design, some with grease lubricated mechanical seal for short dry running.

Connections:

suction socket axial or side wards pointed, discharge socket upwards. Thread socket or flange-execution.

Temperature: up to 100 °C

Capacity: up to 1200 m³/h

Delivery head: up to 60 m

Suction lift: up to 7,5 m

Shaft sealing: mechanical seal

Materials:

casing, impeller and

wearing plate: cast iron, bronze, stainless steel

shaft: chrome steel or stainless steel

Driver: electric motor, gasoline or diesel engine

Power transmission: block-pump i.e. motor shaft = pump shaft, flexible coupling, V-belt

Small selfpriming ship centrifugal pump

Application:
Shipbuilding: as cooling water-, bilge-, ballast-, fire-extinguishing- and general service pump for boats and small ships.

Design:
single stage, horizontal, selfpriming

Connections:
suction- and discharge socket upwards pointed with thread socket or flanges

Temperature: max. 80 °C

Capacity: 0,5 - 50 m³/h

Delivery head: 50 m

Shaft sealing: mechanical seal

Material:
casing: bronze G-CUSn5Zn5Pb5
impeller: G-CUSn10
shaft: chrome nickel steel

Driver: electric motor, diesel engine, V-belt pulley, manual clutch, magnetic clutch



Deep well centrifugal pump

Thread version up to 100 m³/h

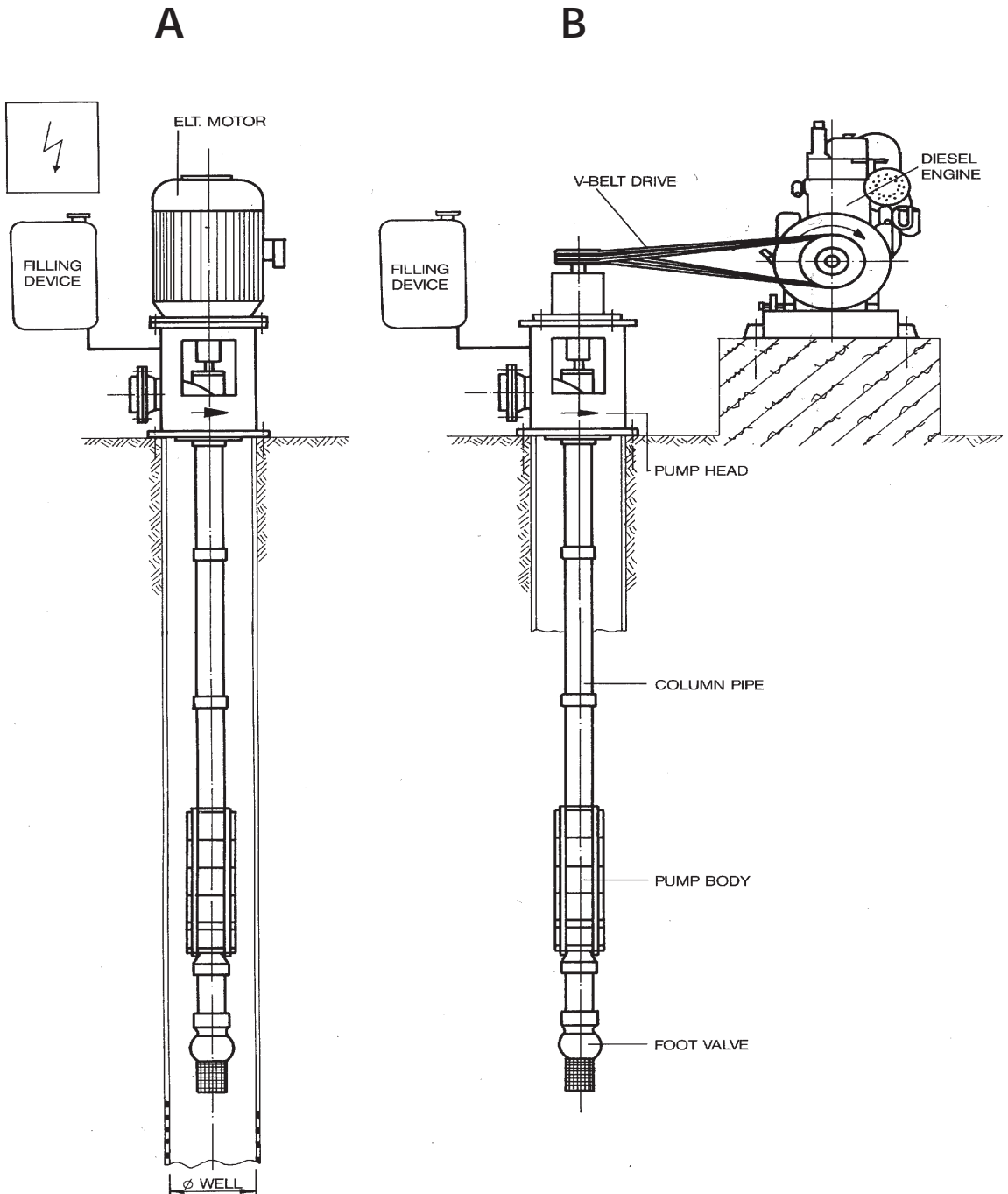

Deep well centrifugal pump

Tread version up to 100m³/h

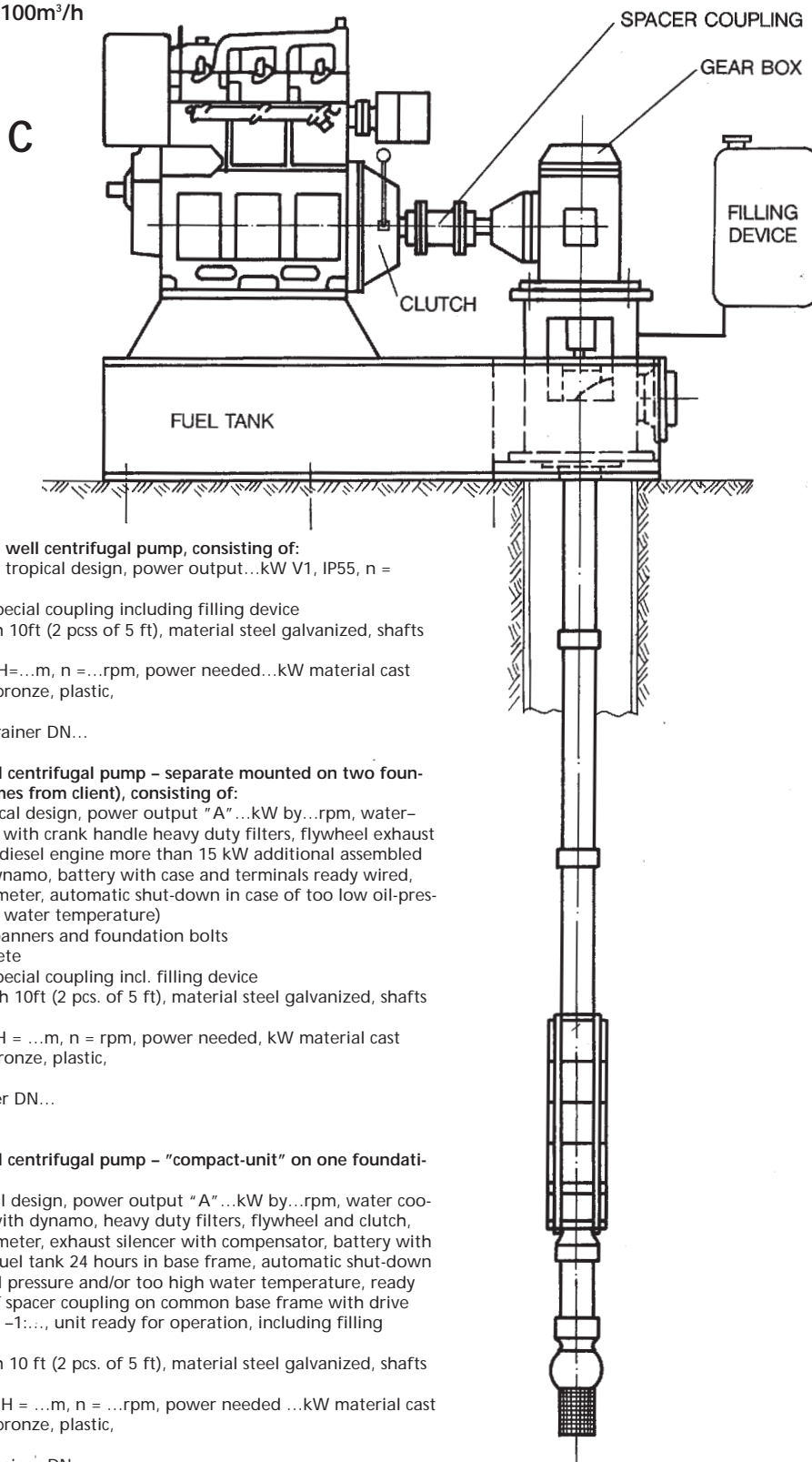

A Electrically driven deep well centrifugal pump, consisting of:

- t.e.f.c. electric motor tropical design, power output...kW V1, IP55, n = ...rpm
- 1 pump-head with special coupling including filling device
- ...column pipes, each 10ft (2 pcs of 5 ft), material steel galvanized, shafts stainless steel
- 1 pump Q = ...m³/h, H = ...m, n = ...rpm, power needed...kW material cast iron, stainless steel, bronze, plastic,
- 1 suction pipe
- 1 foot-valve with strainer DN...

B Diesel driven deep well centrifugal pump – separate mounted on two foundation bases (base frames from client), consisting of:

- 1 diesel engine tropical design, power output "A"...kW by...rpm, water-cooled, manual start with crank handle heavy duty filters, flywheel exhaust silencer fuel tank (if diesel engine more than 15 kW additional assembled with electric start, dynamo, battery with case and terminals ready wired, manometer, thermometer, automatic shut-down in case of too low oil-pressure and/or too high water temperature)
- 1 base frame with spanners and foundation bolts
- 1 V-belt-drive complete
- 1 pump-head with special coupling incl. filling device
- ... column pipes, each 10ft (2 pcs. of 5 ft), material steel galvanized, shafts stainless steel
- 1 pump Q = ...m³/h, H = ...m, n = rpm, power needed, kW material cast iron, stainless steel, bronze, plastic,
- 1 suction pipe
- 1 foot-valve with strainer DN...

C Diesel driven deep well centrifugal pump – "compact-unit" on one foundation base, consisting of:

- diesel engine tropical design, power output "A"...kW by...rpm, water cooled, electric starter with dynamo, heavy duty filters, flywheel and clutch, manometer, thermometer, exhaust silencer with compensator, battery with case and terminals, fuel tank 24 hours in base frame, automatic shut-down in case of too low oil pressure and/or too high water temperature, ready coupled by means of spacer coupling on common base frame with drive and right angle gear -1:..., unit ready for operation, including filling device.
- ...column pipes, each 10 ft (2 pcs. of 5 ft), material steel galvanized, shafts stainless steel.
- 1 pump Q = ...m³/h, H = ...m, n = ...rpm, power needed ...kW material cast iron, stainless steel, bronze, plastic,
- 1 suction pipe
- 1 foot - valve with strainer DN...

VN - Pumpen

Pumps

Deep well centrifugal pump

Section drawing of deep well centrifugal pump
- flanged design

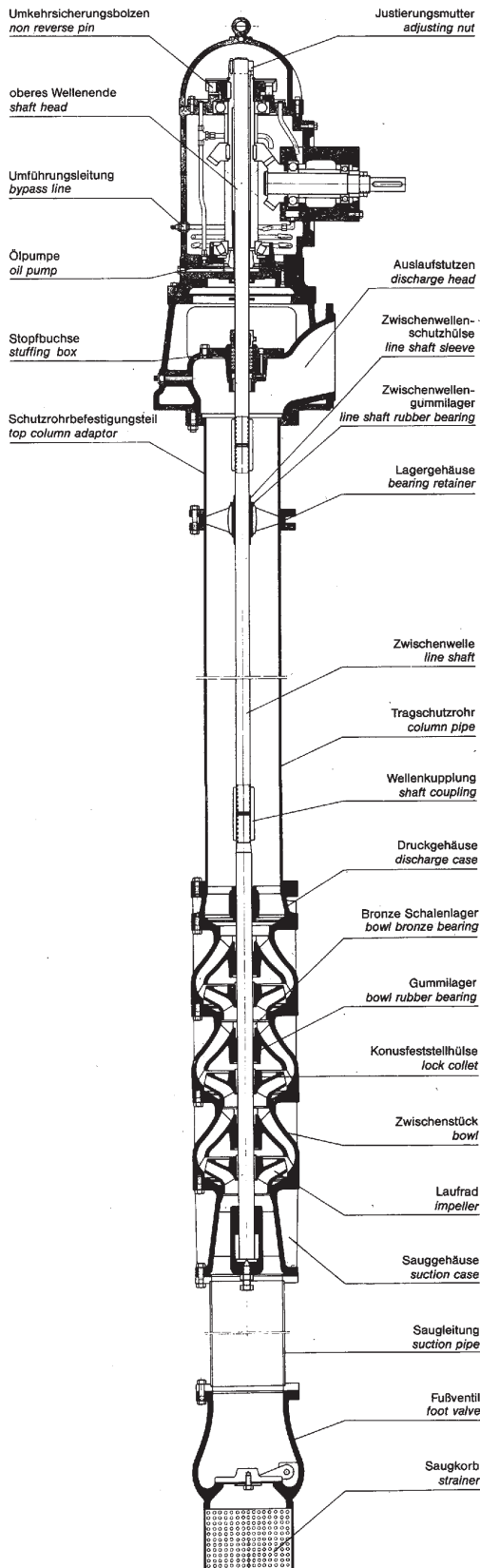

Delivery possibilities for pumpheads with driver

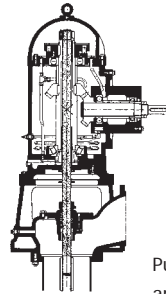

Pumphead with hollow shaft electric motor

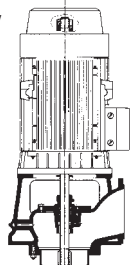

Pumphead with right angle gear drive

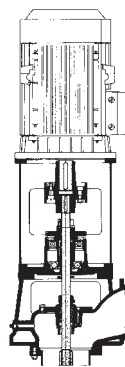

Pumphead with flat pulley

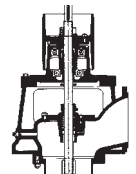

Pumphead with v-belt pulley

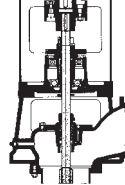

Pumphead with thrust bearing and flexible coupling for standard t.e.f.c. electric motor

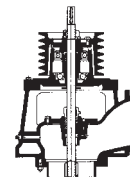

Deep well centrifugal pump

For capacity range up to 1500 m³/h



Several designs of diesel driven deep well centrifugal pumps, upper "compact - unit"

Materials:
cast iron bronze stainless steel



Electrically Driven Submersible Pump

Application:

Drinking water supply to cities and communities, housing pumps, booster-stations, water supply for industrial and commercial use, irrigation plants, drainage, fountain systems, air-conditioning systems.

Design:

Vertical, multi-stage high pressure centrifugal pump with semi-axial or radial impellers, built-in non-return valve with submersible electric-motor and vulcanized submersible electric cable.

Connections:

suction connection: with strainer between pump and electric motor

discharge connection: threaded sleeve or flange

Temperature: suitable for clean cold water, temperature up to max. 40° C. Special design for warm water supply for approx. 80° - 90°C.

max. capacity: 1200 m³/h

max. total head: 1000 m

Materials:

casing: cast iron, stainless steel or bronze

impellers: bronze, stainless steel or plastic

shaft: stainless steel

Drive:

Electric motor, single phase and three phase as squirrel-cage motor. Submersible motor in collimator execution, which is filled with operating fluid including anti-freeze agent before leaving the factory. Three phase motor for direct online starting, over 3 kW for direct online, starting with transformer, starting with soft-starter, or for star-delta starting.

Power transmission: Rigid sleeve – coupling

Bearing: medium lubricated sleeve bearing

Horizontal installation is possible; depending on size of the pump a certain amount of inclination has to be provided.

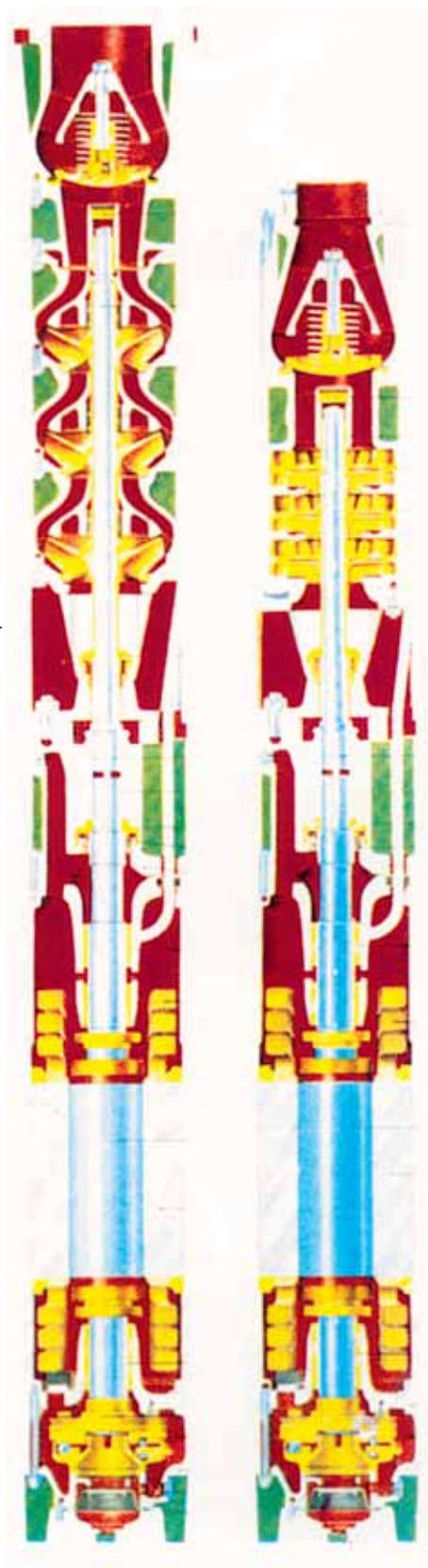

Electrically Driven Submersible Pump

Calculation of necessary cable cross section for total cable length between switch board and pump

Max. current carrying capacity for switching direct on line (1 cable)

Max. current carrying capacity for switching star-delta (2 cables)

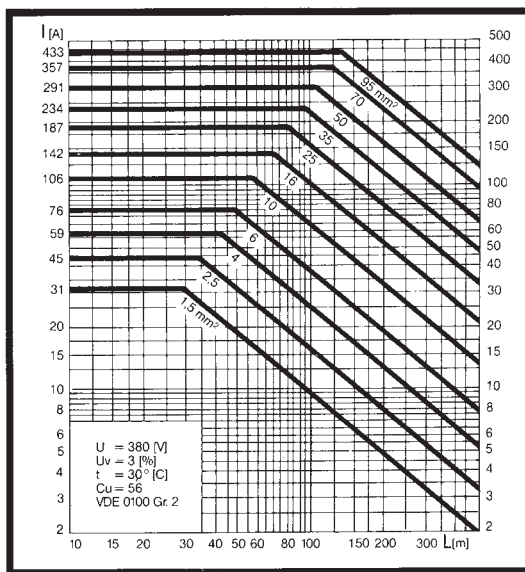
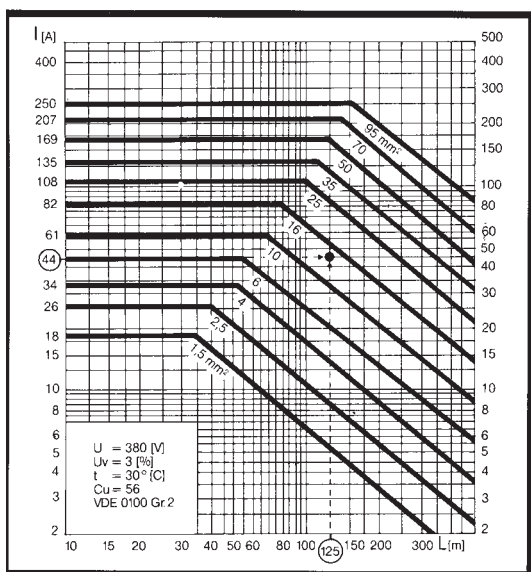

Electrical conductivity from submersible-cable HO 7 RN-7 (DON 57282) at an ambient temperature between 20 °C and 55 °C

Ambient temperature	current carrying capacity at an ambient temperature of:
t (°C)	(%)
20	100
25	100
30	92
35	85
40	75
45	65
50	53
55	38

Switchboard for d.o.l. / star delta-switching 3x ...V/...Hz with following components:

- 1 steel casing
- 1 set of fuses
- 1 motor protection/star delta-switch with term. overload relay
- 1 voltmeter
- 1 volmetric commutator
- 1 amperemeter
- 1 amperemetric commutator
- 1 door lock
- 1 operation lamp
- 1 alarm lamp

Dry running protection consisting of:

- 1 electronic relay built in a.m. switchboard
- 1 electrode probe
- 2 electrodes
- 2x ...m electrode-submersible cable

VN - Pumpen

Waterworks with electric submersible pumps

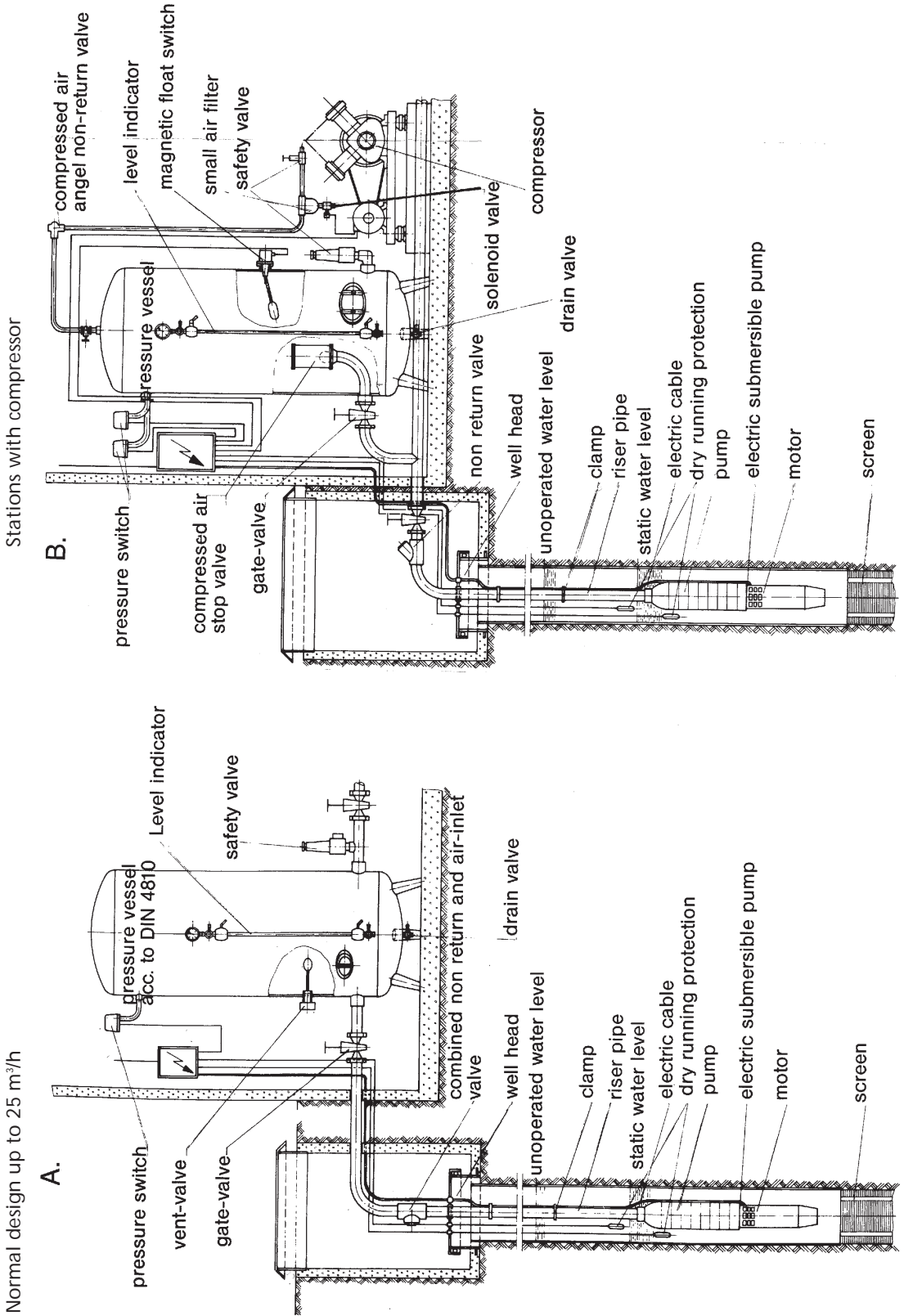

Waterworks with electric submersible pumps

Design for irrigation sprinkler (by means of additional booster-pump)

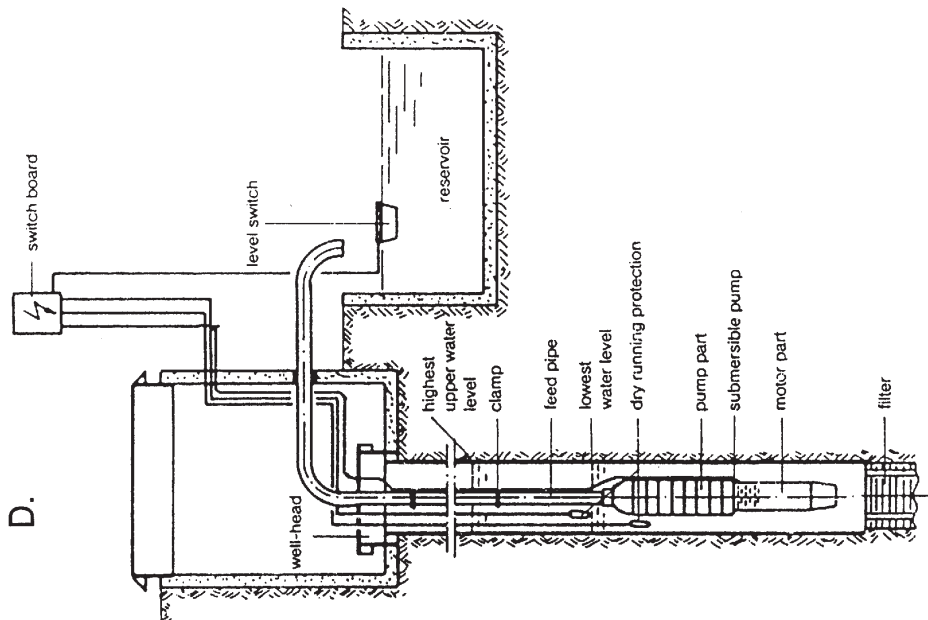

Mode for continuous water supply and automatic operation

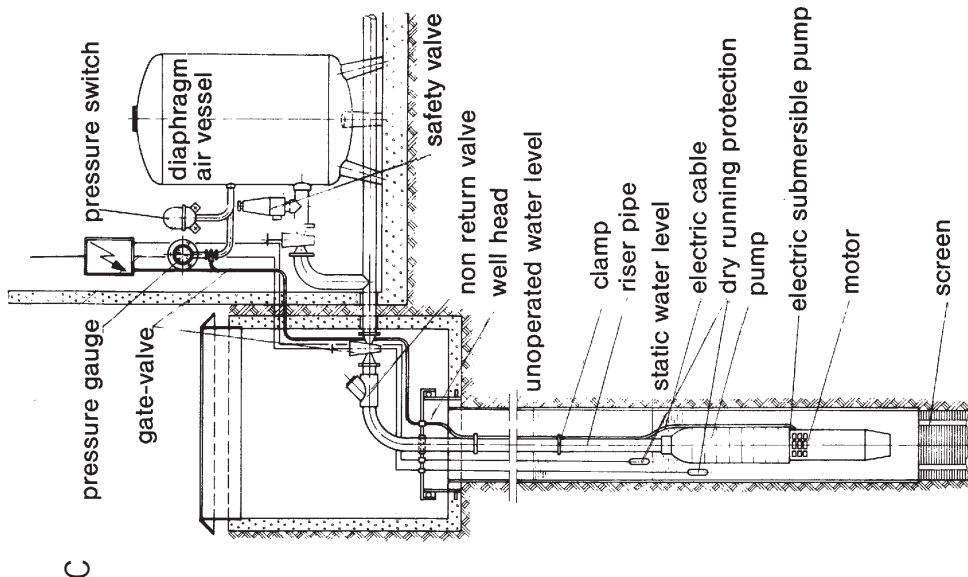

Please give us with your inquiry the required installation according: A, B, C, D.

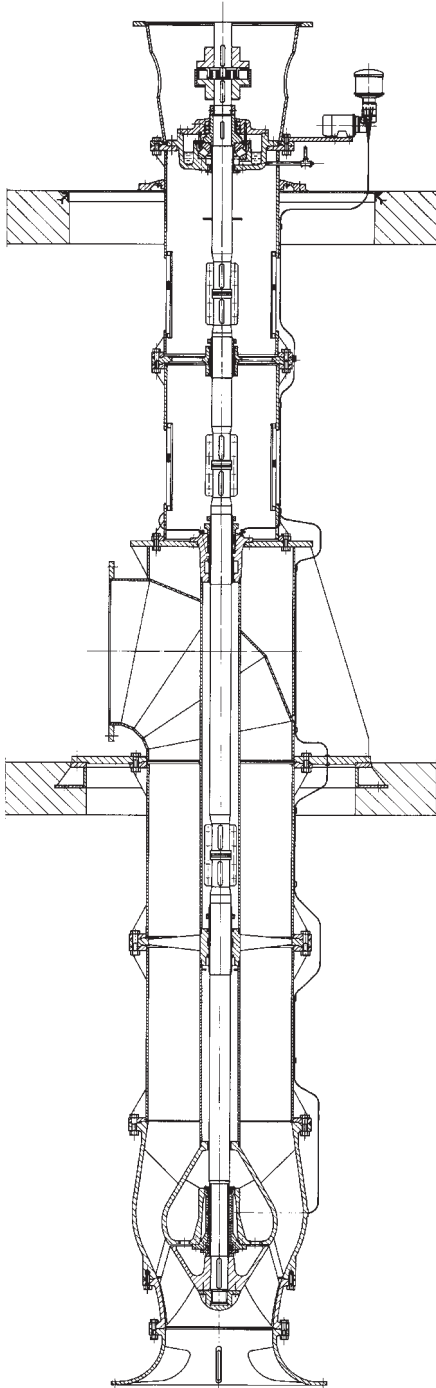

Axial flow pump

Vertical, single-stage centrifugal pump, low pressure pumps with large quantity of liquid for drainage and irrigation, for rain water, mixed waste water, muddy water, cooling water and water for industrial supply. The liquid must be pre-settled and chemically neutral and the temperature should not rise above 60° C.

The impeller blades are inserted into the impeller hub singly. Thus the angle of the blades can be modified when operating conditions change or individual blades renewed if they become damaged.

Design dimension: DN 200 up to DN 1400
Capacity range: up to 20 000 m³/h
Delivery head: up to 10 m
Driver: electric motor, electric gear motor, diesel engine with angle gear or V-belt.



Mixed flow pump

As described before, but for medium-sized heights that means delivery head up to 30 m

Complete submersible model available.

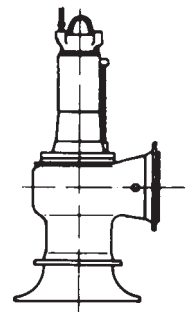

One of the mixed flow pumps used in a drainage pump station in the Middle East



4

Delivered pumps for $Q = 20.000\text{m}^3/\text{h}$, $H = 20\text{ m}$

Motor for a.m. pump 1600 kW 423 RPM ▶



27

Dewatering pump

electric submersible pump for dewatering, low pressure



Application:

for automatic discharge of dirty water out of dewatering pits in cellars, lavatories or store-rooms, for backwash safety in case of high water level.

Design:

vertical, single stage, submersible pump, with strainer, with open impeller for max. solids of 10 mm.

Discharge socket: female thread 1 1/4"

Temperature: normal 40 °C, max. 90 °C

Shaft sealing: radial sealing rings

capacity range: 1 - 25 m³/h

delivery head: 1 - 10 m

Materials:

casing: aluminium castings, cast iron, stainless steel, plastic

impeller: GFK, ALSI 12, GG 20

shaft: stainless steel

Driver:

submersible electric motor, protection IP 68, single phase 230 V, 50 Hz, three phase 3 x 400 V, 50 Hz (special voltage possible)

Bearing:

2 ball bearings

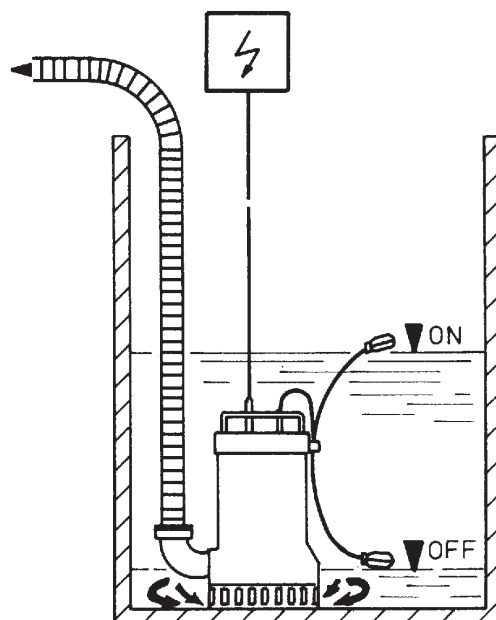



Dewatering pump

Electric submersible pump for dewatering, middle pressure

Application:
for discharge of dirty and muddy water out of excavations and dewatering pits

Design: vertical, single- or two stage, submersible pump, with strainer, with open impeller for solids of 6 up to 20 mm

Discharge socket: female thread or quick coupling

Temperature: normal 40° C, max. 90° C

Shaft sealing: mechanical seals with oil chamber

Capacity range: 10 - 500 m³/h

Delivery head: 1 – 40 m

Materials:
casing: aluminium casting, cast iron, inside rubberized

impeller: ALSI 12, cast iron, bronze, hard metal

shaft: stainless steel

Driver: submersible electric motor, protection IP 68, single phase 230 V, 50 Hz, three phase 3x400 V, 50 Hz (special voltage possible) up to 3 kW direct on line, over 4 kW star-delta

Switching: Starter with motor protection, hand-automat-selecting-switch, cable and plug. For automatic operation with level switch. Three-phase version available with switch for reversal of rotation.

Bearing: 2 ball bearings



VN - Pumpen

Pumps

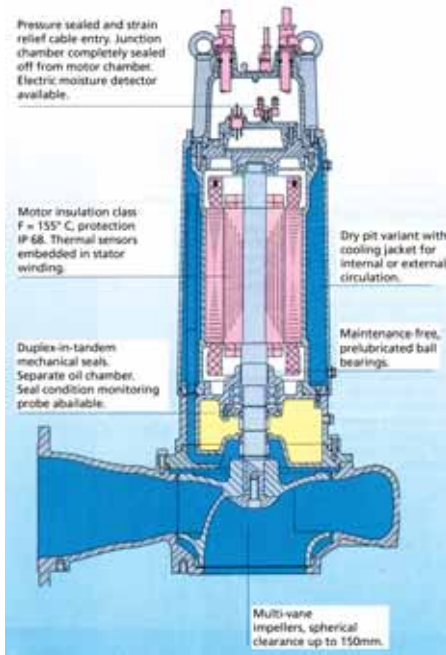

Sewage dewatering pump

Application: For industries, trade business and municipal undertaking for handling sewage such as long-fibred coarse materials (sanitary pads, tissue) specially in undergrounds, swimming pools, hospitals, paper factories, utilizing plants, hotels, camping places etc.

For the choice of right pump you have to consider:

- application of pump
- necessary diameter of free-flow
- if sewage is non-treated or treated

Design: vertical, single-stage, submersible with special impeller, one-vane-impeller or free-flow-impeller, for following max. solids: mini-model = 45 or 70 mm, all other sizes acc. to the diameter of discharge socket without danger of clogging.

Pump with foot and hose-connection, or with self-coupling slipway system.

Connection: sideways pointed flange

Shaft sealing: mechanical seals with oil chamber

Capacity range: 10 - 1000 m³/h

Delivery head: 1 - 40 m

Materials: casing and impeller cast iron, shaft stainless steel

Driver: submersible electric motor with, protection IP 68, three phase 3x400 V, 50 Hz, (special voltage possible), furthermore explosion-proof version, PTB-type-approval. Up to 3 kW direct on line, 4,0 kW and more for star delta. (mini-model available for single phase 230 V, 50 Hz)

Bearing: 2 ball bearings

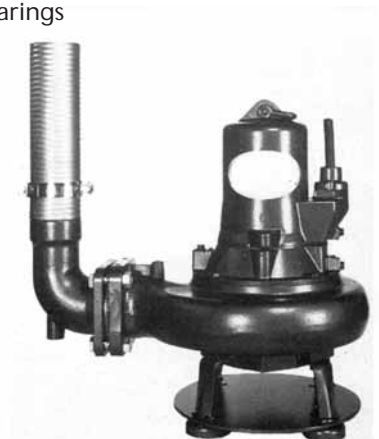

Accessories for dewatering and sewage submersible pumps

Permanent wet well installation
with elbow discharge connection

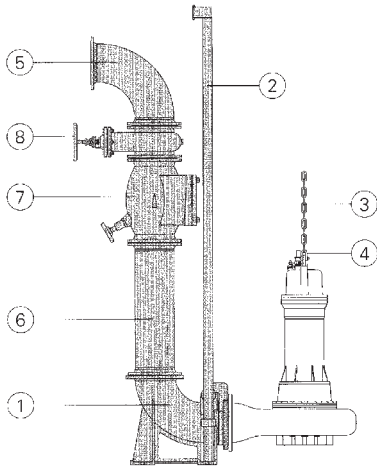

Permanent dry well installation
vertical

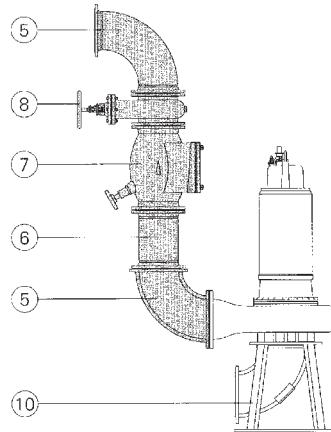

1) Auto-coupling system consisting of auto-coupling with flanged elbow, flanged pump coupling and upper slide rail bracket

2) Steel galvanized guide rails

3) Steel galvanized lifting chain

4) Steel galvanized shackle

5) 90° flanged elbow (or flanged y-piece for twin pump arrangement), horizontal discharge (optional with vertical discharge) available with different dimensions according to sump dimensions

6) Flanged discharge pipe with gasket and fixing bolts or hose with quick couplings

7) Flanged swing check valve with gasket and fixing bolts

8) Flanged gate valve with gasket and fixing bolts

9) Ring base stand

10) Pump stand with 90° suction elbow with cleaning hole, gasket and fixing bolts

Wet well installation with
supporting ring

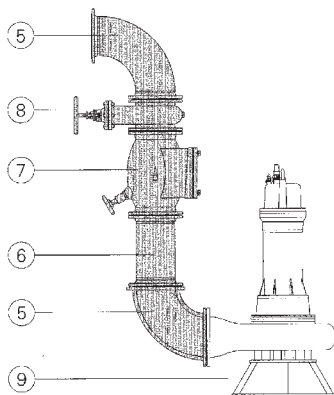

Horizontal installation

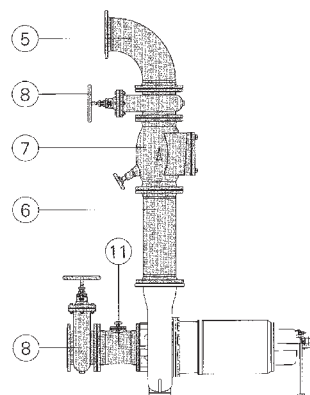

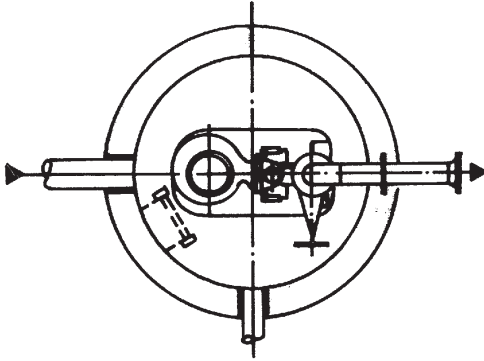

Waste water pump

The automatic coupling provides swift and systematic installation and starting-up of the pumps. The base is mounted on the shaft-floor of the pump installation and is linked to the delivery output. A conductor joins the base to the box spanner on the shaft opening.

The immersion motor pump is suspended from the conductor and is gently lowered.

It then automatically finds its operating position and the pressure connection at the base is made watertight due to the pump's own weight.

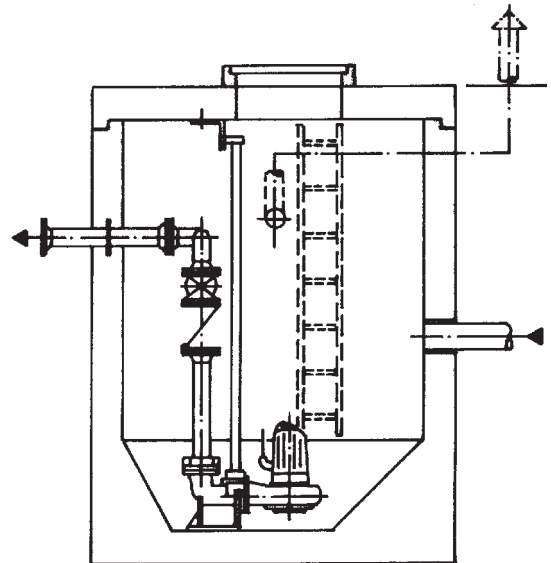
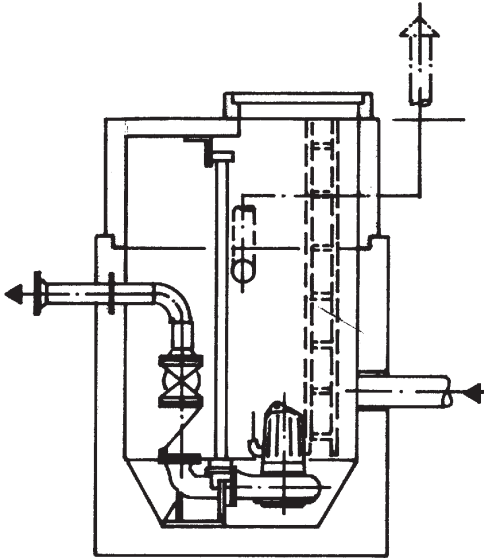

For fixed-installations with base and mono-pipe conductor or for portable usage or fitting onto containers there is an extensive accessories programme. We supply fully fitted control centres with various optional extras such as floating switches or the pneumostat electro-pneumatic level control. These are for automatic control of single or dual pump stations.

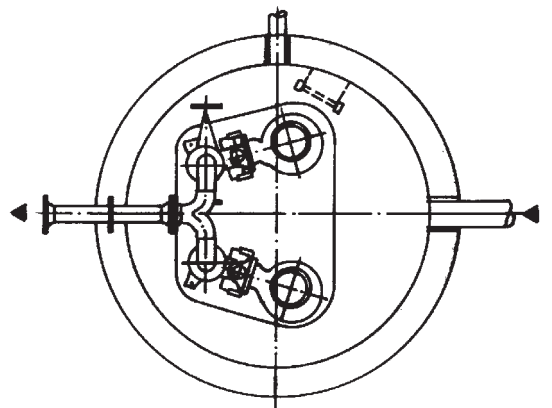

Electric sewage dewatering pump station inside closed buildings

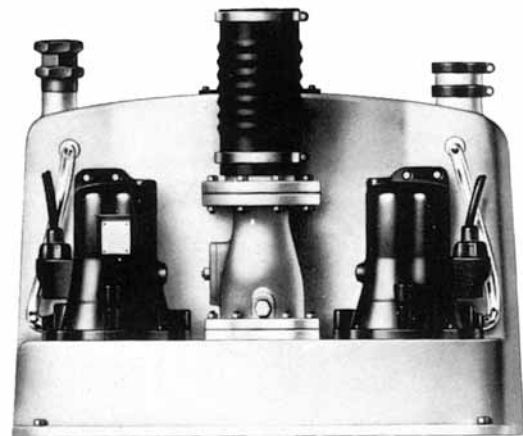

Packaged sewage disposal unit with 1 pump

Packaged sewage disposal unit with 2 pumps

Design acc. to DIN 1986 with approval

Application: acc. to DIN 1986 all sewage must be pumped out with a pump station, if surface of toilet is less than 250 mm over back wash water table. For installation in closed rooms this pump station must be designed as packaged tank units which are freestanding, smell-tight and gastight.

- mini-station for single toilets or single family houses
- station with 1 pump for multifamily houses
- station with 2 pumps for hotels, restaurants, department stores, schools

Design: automatically operating packaged sewage disposal unit consisting of: tank with cleaning opening, 1 or 2 pumps with motors, switchboard, automatic level control unit with transformer, alarm device, emergency hand pump, non-return valve and gate valve

Temperature: max. 75 °C

Driver: electric motor, submersible version is also available

Switching: automatic operation by means of level control unit, switchboard with supervision, up to 2,2 kW for starting direct on line, 3 kW and more for star delta starting with alarm device audible and visible, independent of mains.

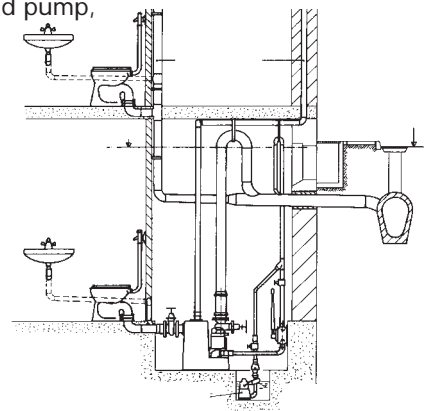

Crude waste and sewage handling pump

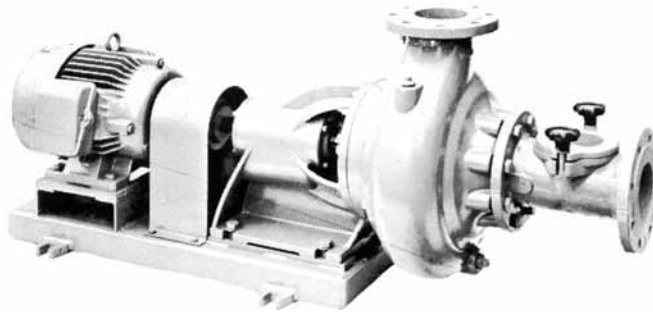

Application:

handling of waste water in sewage treatment plants, breweries, slaughter houses etc; treated domestic- and industrial-sewage, faeces, sanitary sewage, mud etc.

Design:

single stage, non-self-priming centrifugal pump, horizontal or vertical, bigger models with cleaning opening at the casing or inlet-socket. Pump can be delivered with
 - enclosed single-port, twin-port or three-port impeller
 - open single-port, twin-port or three-port impeller.

Kind of impeller depends on required max. solids. Pump can be equipped with an automatic fibre chopping device made of highly wear-resistant cast iron, which prevents fibrous material from clogging the pump.

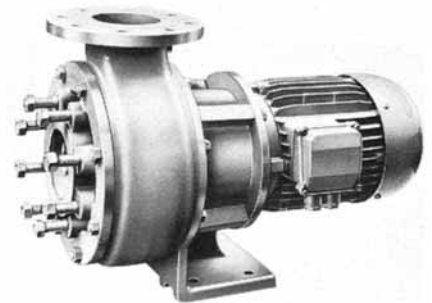

Connections:

suction socket axial, discharge socket various possibilities. Flange connection.

Temperature:

max. 110 °C

Capacity range:

5 – 3000 m³/h

Delivery head:

max. 95 m

Shaft sealing:

stuffing box, mechanical seal

Materials:

casing, impeller and wear plate: cast iron, bronze, stainless steel, highly wear-resistant cast iron

shaft: steel, stainless steel

sleeve: chrome steel, bronze, stainless steel

Driver:

electric motor, diesel engine, electric submersible motor, also explosion- and flame-proof motors

Direction of rotation:

cw

Power transmission:

flexible coupling, V-belt, direct flanged i.e. motor shaft = pump shaft

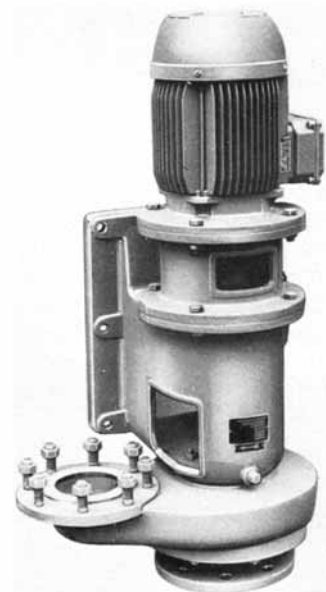

Crude waste and sewage handling pump

Special design:

vertical dry- or wet-installation. The top supporting plate is connected with the lantern including the thrust bearing for the drive-shaft. Shaft and motor assembled by means of flexible coupling. Below the supporting plate the shaft protection pipe is flanged. Corresponding to the length, this protection pipe consists of one or several intermediate pipes and bearings, in which the rigid coupled intermediate shafts are supported. At the end is the pump body with inlet casing, pump shaft and impeller. The liquid is pumped out of sideways pointed discharge socket, or through parallel to protection pipe mounted discharge pipe above supporting plate. Shaft sealing can be delivered with stuffing box, but we recommend mechanical seal or better double mechanical seal with oil filling, because this design is absolutely dry-run-proof.

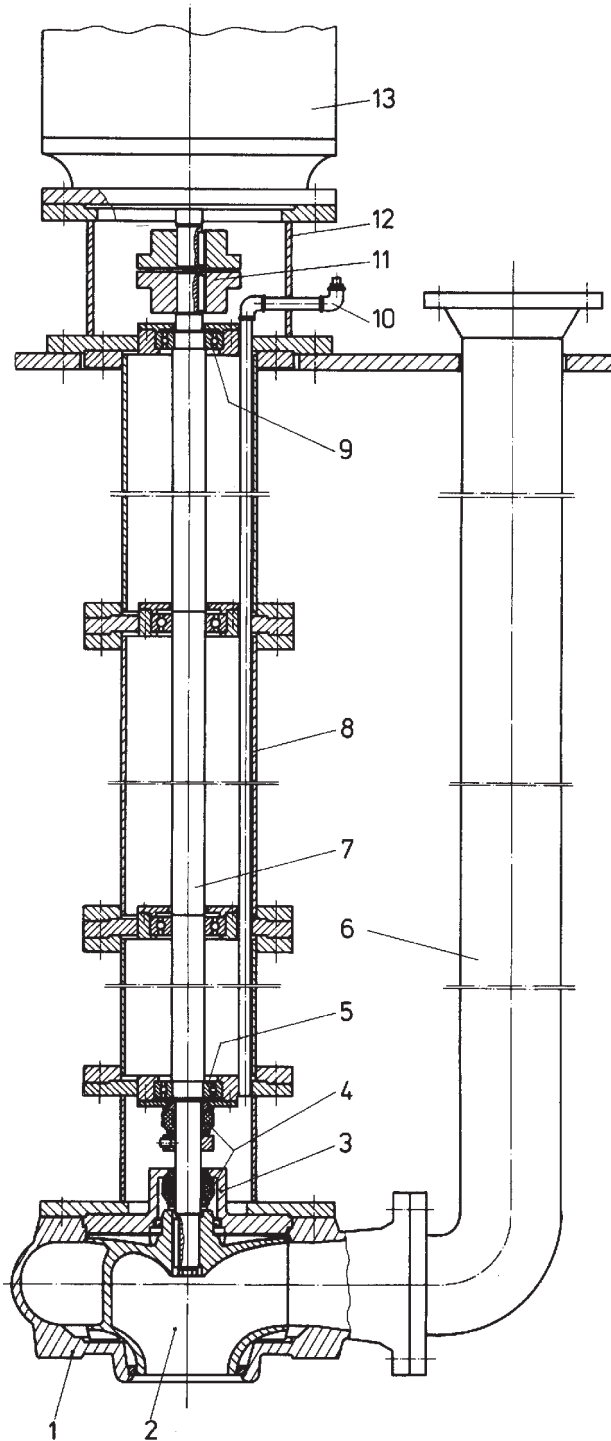

- 1 pump casing
- 2 impeller
- 3 pump cover
- 4 mechanical seals
- 5 ball bearing
- 6 discharge pipe
- 7 shaft
- 8 column pipe
- 9 thrust bearing
- 10 oil fill in connection
- 11 flexible coupling
- 12 motor support
- 13 electric motor

Electric submersible pump made of bronze or stainless steel



Material bronze for seawater as portable loading or off-loading pump, bilge or ballast pump.
Material stainless steel for pumping corrosive and abrasive mediums, aggressive chemical drainage water or sludge and chemicals.

Application:
for discharge of dirty and muddy water out of excavations and dewatering pits

Design: vertical, single- stage, submersible pump, with open impeller for solids of 10 up to 30 mm

Discharge socket: flange

Temperature: normal up to 40 °C, max. 90 °C

Shaft sealing: mechanical seals motorside carbon / ceramic mediumside sic / sic

Capacity range: 5 - 72 m³/h

Delivery head: 1 – 40 m

Materials:
casing and impeller: marine bronze
casing or impeller: stainless steel 1.4401
shaft: stainless steel

Driver: submersible electric motor, protection IP 68, three phase 3x400 V, 50 Hz (special voltage possible) up to 3 kW direct on line, over 4 kW star-delta

Bearing: 2 ball bearings



Diaphragm pump



The diaphragm pump is a slow speed positive displacement pump with non-clogging valves. Diaphragm pumps can pump sewage- and muddy water and even slurry. Special features:

- Self-priming
- Non-clogging
- Can run dry
- Sturdy design
- Long service life

Capacity:	up to 42 m ³ /h
Delivery head:	10-15m
Driver:	electric motor or gasoline/diesel engine
Connection:	thread sockets



Compressed air-driven diaphragm pumps

Benefits at a glance:

- gentle conveyance of liquid or viscous products
- ideal for abrasive, viscous and shear sensitive media
- can handle media with entrained solids
- tolerant of dry running
- no dynamic or pressure loaded seals
- mobile, easy-to-transport units
- infinite regulation of pumping capacity
- dry self-priming
- can run against closed valves
- compressed air control, oil free
- submersible designs
- suitable for use in explosive and hazardous areas



Main application fields:

on board of vessels as stripping pump, in civil engineering for emptying tanks, water accumulation, pits and cable trenches

Design:

selfpriming vertical portable pump for compressed air -drive.

Materials:

Housing: aluminium, cast iron, stainless steel 316L, polypropylene, PVDF, PTFE

valve seat, valve ball, diaphragm: NRS, EPDM, Viton, EPDM-grey, Nitrile, PTFE

Connections:

female thread, flange, quick-coupling

Capacity:

0,1.....40m³/h

Total head:

max. 7 bar

Suction lift:

up to 8,5 m

Viscosity:

up to 18 mm²/s

Accessories:

- silencer
- maintenance-unit of pressure gauge, filter and needle valve 3/4"
- slow-start-valve adjustable 1 - 10 sec.



Compressed air-driven, dirt resistant submersible pump

Application:

Portable loading and off-loading pump for handling of pure or slightly polluted liquids, which do not chemically or mechanically attack the construction materials of the pump.

Main application fields:

on board of vessels as stripping pump, in civil engineering for emptying tanks, water accumulation, pits and cable-trenches.

Design:

vertical portable pump for compressed air drive, filter and compressed air connection cock.

Connections:

compressed air connection: $\frac{3}{4}$ "
water connection: $1\frac{1}{2}$ " female thread

Driver:

built-in air motor. Compressed air pressure 6 – 8 bar



Max. capacity by air pressure of 6 bar and 5 m head, 100 m³/h
Max. head: 60 m

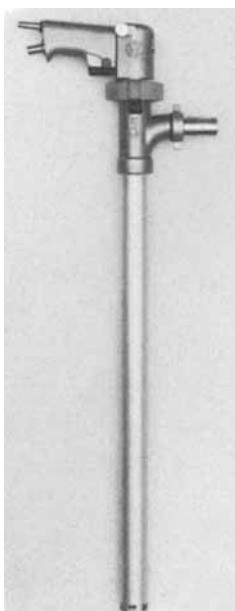

Barrel and container pump

Application:

for all neutral, corrosive, flammable, thin or highly viscous, pasty, creamy and aerated liquids. Pump is a light weight, fully portable or stationary barrel and container pump. Stirring and mixing are readily achieved, even in narrow-necked vessels, by fitting a mixing tube.

Design:

Motor heads and pump tube sets are interchangeable according to application. Motor head is surface-cooled, fitted with an insulated handle and a built-in switch and with 5 m cable and plug. Each pump tube has an inner and outer tube, inner tube carefully sealed. Pump tube set is secured to the motor head by a union nut and is easily removed for cleaning. The liquid is pumped upwards between the outer and inner tubes to the outlet. When lifted from the liquid, the pump set drains completely. Pump sets available in lengths of 700, 1000 and 1200 mm.

Connection:

discharge socket sideways below motor head

Temperature:

up to max. 120 °C (temporary) depending on material and liquid.

Capacity range:

0,1 – 60 m³/h

Delivery head:

up to 2 bar

Shaft sealing:

shaft seal is made of material compatible with the liquids to be pumped i.e. perbunan, viton, ceramics and hard carbon. Special seals available on request. Also available in sealless version.

Materials:

Pump tube set: aluminium alloy (AlMg 5), stainless steel 1.4571, hastelloy C, polypropylene, PVDF

Impeller and Bearing case:

stainless steel, polyamide, polypropylene, PTFE

Shaft:

stainless steel, hastelloy

Driver:

double insulated splash proof commutator motor 240, 230, 110, 42 V AC, 24 V AC/DC, 12 V DC, or gear motors for single- or three-phase current, explosion proof (Ex) d3nG5, (Ex) dC3 (T4), dIIBT6, class 1 group C and D. With compressed air motor.

Power transmission:

coupling

Bearing:

sleeve bearings

Viscosity:

up to 1000° Engler (7580 cp)

Tested:

to German, Swiss, American and Canadian standards.

Dosing and Transferring Pump

Applicable for nearly all kinds of liquids (such as: acids, brines, solvents and others) can be delivered as: single pump, multiblock pumps, combination pumps, complete dosing and control systems and small dosing units.

Materials:

All parts in contact with the liquid are selected according to the medium to be pumped. We can deliver dosing pumps with following materials: PVC, PE, PTFE, titanium, steel with hard rubber lining, corrosion and acid resistant steels, perbunan, hypalon and viton.

Regulation:

The capacity of the pump is constant and infinitely adjustable. Regulation is done by changing the stroke and/or by changing number of stroke. For this purpose the pump is provided with a scale-hand adjusting knob or with control gear motor including hand-wheel. Electrical control by a servo motor or pneumatic control by a small air motor. D.C. motors with Tyristor – control units can be delivered to use alternating current mains.

Automatic dosing plants:

The proportional control of dosing volume is carried out as a function of the measured value on a contact flow meter: the pump gives a full stroke volume of flow for each water counting impulse. Fully automatic dosing dependent on a main flow meter: continuous dosing proportional to the measured flow of main flow meter.

Proportional dosing depending on analogue measuring values (current, voltage, resistance). Direct dosing control of the pump is made by the converting of an input value to a proportional impulse frequency. Electronically controlled systems can be delivered for automatic control of the ph-value. Dosing value is controlled by automatic comparison of measured value to the preadjusted rated value. Charge dosing with digital flow preselection: the pump is shut off automatically after arriving at preadjusted dosing value.

Small dosing plants:

Dosing pumps, tanks and fittings mounted to a compact unit (tanks in polyethylene or steel). Units complete with foot valve, hand- or electric-mixer and with all other accessories such as dosing point connection, overflow valve, ball valve. These systems are robust, reliable and ideal for continuous operation.

Hydrazin dosing plants:

are installed on the water / steam systems for dosing of Hydrazin to avoid corrosion by binding of oxygen. This kind of plant is gas tight and fulfils the safety regulations of the industrial control societies.



Piston diaphragm dosing pump



Aluminium Sulphate solution dosing compact units

Dosing and Transfer Pump

Application:

Sewage neutralization and water treatment:

Chemical dosing for precipitating and flocculating agent

Car wash plants:

Dosing of cleaning agents in fluid form, shampoo and wax into wash water.

Chemical industry:

Dosing and transfer of various neutral and aggressive fluids for chemical processes.

Paint and varnish industry:

Dosing of paint and varnish components in fluid form and dosing of solvents.

Photo industry:

Dosing of development chemicals.

Galvanizing process:

Dosing of concentrates on pickling and galvanizing plants

Food and beverage industry:

Dosing of flavour agents and fruit concentrates, dosing of sugar solutions for production of malt beer, dosing of aux. filtering agents and stabilizers, dosing of bottle-cleaning agents.

Animal food production plants:

Fat and soya bean oil addition, spraying and luprosil dosing.

Food industry:

Dosing of vitamin and sugar solutions, protein and flavour agents.

Margarine production:

Dosing of soya bean oil and salt solutions.

Dairy-plants:

Dosing of colour agents into fruit juice, yoghurt and marmalades. Dosing of salt solution for butter production. Dosing of water treatment and cleaning chemicals.

Paper industry:

Chemical dosing of colour agents, bleaching agents and solvents.

Pharmaceutical industry:

Dosing and transfer of brines and solvents.

Nuclear power plants:

water and sewage treatment, sample testing.

Swimming pools:

Dosing of chlorine solutions for disinfection, dosing of aluminium sulphate for flocking.

Textile industry:

Dosing of colour agents, acids and brines.

Sugar industry:

Dosing of lime milk for neutralization, kieselguhr for drifting filter, and dosing for acids for leaching.



Diaphragm dosing pumps

Gas dosing systems

Different versions for various applications

A Modular System

- vacuum regulator for direct mounting on a gas cylinder
- dosing regulator for separate wall mounting
- up to 10 m of vacuum line between both devices

A

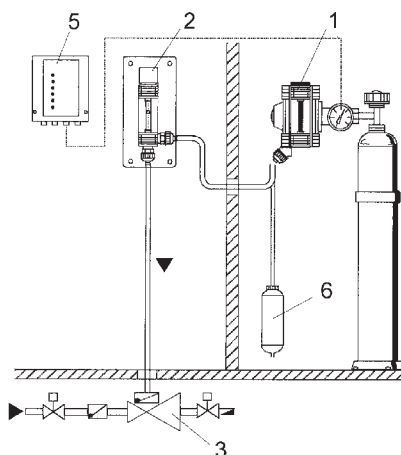

B Dosing system with vacuum change-over device

- for continuous gas dosing without interrupting the process
- 2 vacuum regulators for mounting on gas cylinders
- single or multiple dosing regulator for separate wall mounting
- the first cylinder being empty, the device changes over immediately to the next vacuum regulator at the full gas cylinder

B

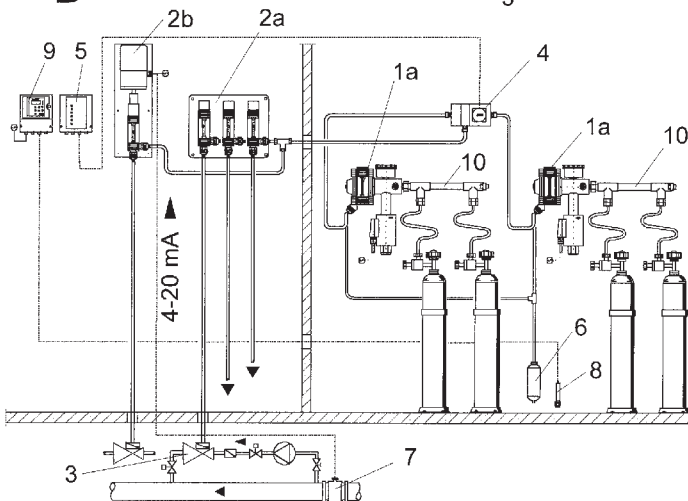

C Dosing system for the simultaneous extraction from several gas cylinders

- if more gas is needed, it can be extracted from several cylinders simultaneously
- vacuum regulators are installed on several chlorine cylinders and switched in series by T-pieces
- single or multiple dosing regulators for separate wall mounting
- with automatic vacuum change-over device

C

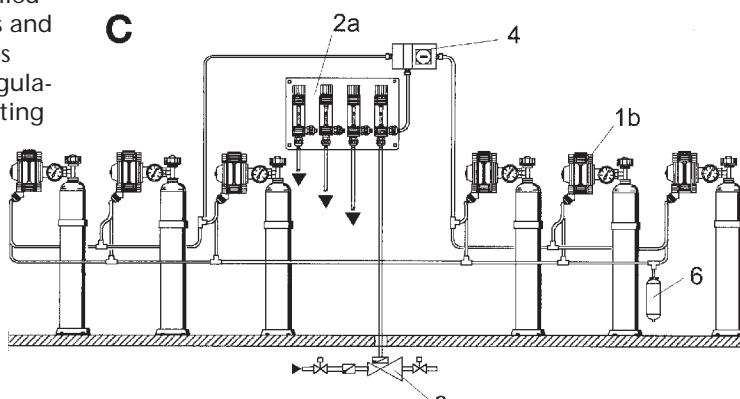

- 1 Vacuum regulator with manometer
- 1a Vacuum regulator with liquid trap (heated)
- 1b Vacuum regulator with serial switching
- 2 Single dosing regulator
- 2a Multiple dosing regulator
- 2b Dosing regulator with electric servomotor
- 3 Injector with non-return diaphragm

- 4 Vacuum change-over device
- 5 Indication unit for empty signal
- 6 Gas absorption cylinder
- 7 Flowmeter with current signal output
- 8 Gas sensor
- 9 Gas warning device Gasetect
- 10 Header line

Circulating pumps

coupled with electric motor

Inline-design

- Application:** for cold- and hotwater circulation, desalinated water, freon, glycol-mixing, and other kinds of liquid, which are circulating pure and slightly polluted liquids, the construction materials of the pump not chemically and mechanically attacking.
- Design:** single stage low pressure centrifugal pump, inline design, for horizontal or vertical installation. Can be delivered as single- or double pump.
- Connections:** suction- and discharge socket same dimension, opposite, flange connection up to DN 200
- Temperature:** - 15 °C up to + 140 °C
- Capacity:** up to 500 m³/h
- Delivery head:** up to 75 m
- Operation pressure:** up to 120 °C max. 16 bar, up to 140 °C max. 13 bar
- Sealing:** mechanical seal, some models, if required, with stuffing box packing
- Materials:**
 casing: cast iron, spheroidal graphite iron, bronze
 impeller: cast iron, bronze, stainless steel
 shaft: stainless steel
- Driver:** 3-phase electric norm-motor, if required single-phase, direct-current-, explosion proof- and pole-changeable-design
- Direction of rotation:** depending on model and size cw or ccw
- Power transmission:** sleeve coupling
- Bearing:** the bearing and load of axial- and radial-forces are taking over from drive side fixed-bearing of motor

Liquid ring – vacuum pump



Application: Vacuum pump is used for compressing dry and wet gases on the plants of chemical and pharmaceutical industry, food-, semi-luxuries- and paper industry.

Water ring vacuum pump used for evacuation of apparatus and piping systems, impregnating, distillation, drying, sterilization, boiling, draining and compressing of explosive and aggressive gases. Furthermore, they can be used on desalination plants for freshwater production, degassing of melted steel, on pneumatic transport systems and for draining.

Design: An eccentric rotor located in cylindrical pump casing transmits the power to a liquid ring, which after starting-up takes a concentric form to the casing. By means of this arrangement, the liquid is displaced from an impeller cell and is sucked into cell again. On the area of the impeller-cell the liquid ring is exhausted. The gas is discharged at the pressure side via an outlet part. During operation the pump must continuously be supplied with service liquid, normally water, in order to eliminate the heat resulting from gas compression and in order to replenish the liquid ring, because some of the liquid leaves the pump together with the gas. The liquid can be separated from the gas in a liquid separator. Re-use of the service liquid is possible.

Liquid ring vacuum pump has the following important features: Almost all gases and vapours can be pumped. The gases being pumped can be saturated with vapour. Small quantities of entrained liquid can be handled. Compression of the gases and vapours being pumped is nearly isothermal. Liquid ring vacuum pump does not require any lubricant in the working space. Reliable operation with minimum maintenance. Low noise and vibration levels. Adaptable to most duties when correct choices of materials of construction and service liquid are made. They can be applied without modification as compressors up to a compression pressure of 1 bar.

Connections: flange connections, suction and discharge radial or tangential upwards.

Shaft sealing: stuffing box or mechanical seal.

Materials:

casing:	cast iron, bronze, stainless steel
impeller:	bronze, stainless steel
shaft:	chrome steel, stainless steel

Driver: electric motor

Direction of rotation: cw

Power transmission: flexible coupling

Bearing: both sides grease lubricated ball bearings

Reciprocating pump

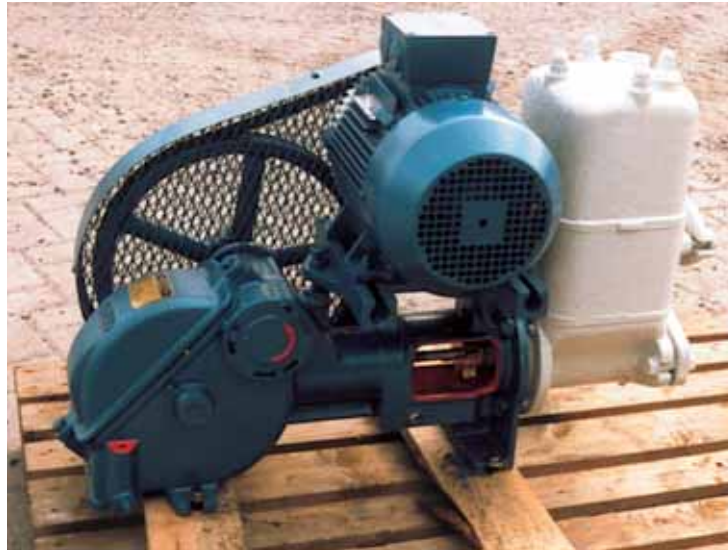

4

Application: Water supply for agriculture, shipbuilding industry as bilge-, stripping- or boiler feed pump.

Design:

up to 5 m³/h horizontal double acting with built-in relief valve, with crank shaft or gear; over 5 m³/h horizontal double acting with gear (relief valve must be installed separately) over 5 m³/h vertical version is available. Some models available with ball-valves for viscous and dirty liquids.

Connection:

up to 5 m³/h oval flanges with threaded counter flanges, other models with DIN-flanges without counter flanges.



Horizontal piston pump direct driven via gearbox



Vertical marine reciprocating pump

Reciprocating pump

Driver:	electric motor, diesel engine, steam	
Power transmission:	V-belt, gearbox and flexible coupling	
Bearing / lubrication:	crank shaft, gears and all bearings oil bath-lubricated	
Temperature:	max. 105 °C	
Capacity range:	0,5 - 250 m³/h	
Pump pressure:	normal version	4 up to 6 bar
	middle pressure version	up to 16 bar
Suction lift:	normal- and middle pressure version up to 7,5 m	
Shaft sealing:	stuffing box	
Materials:	gear casing	cast iron
	pump casing	cast iron, bronze, steel, stainless steel
	cylinder	brass, bronze, stainless steel
	valves	brass, bronze, stainless steel
	valve rings	rubber, buna
	piston rod	stainless steel
	piston and piston rings	cast iron, bronze, stainless steel, rubber, buna etc.

High and very high pressure plunger pump units for all industrial applications

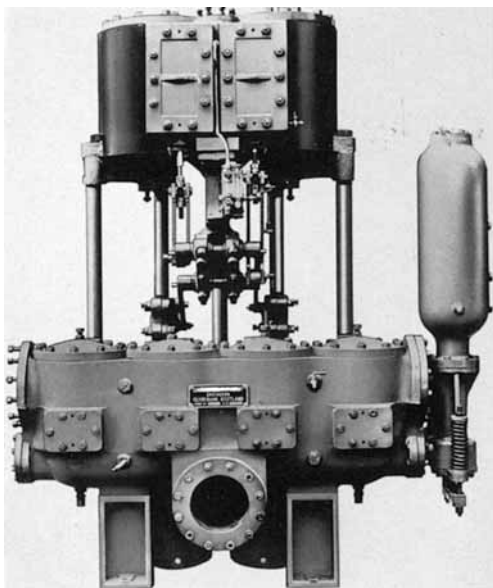

Steam driven reciprocating pump



Mobile driven reciprocating pump
190 l/min - 220 bar

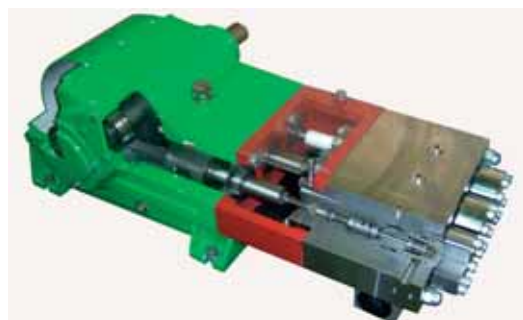

High pressure plunger pump up to
100 m³/h up to 1500 bar

Gear pump



Application:

For pumping mineral oils, respectively fuel oils, pipe line pump and transfer pump; for pumping self-lubricating liquids without abrasive particles in general.

Design:

Self-priming with replaceable bearing inserts, including bearing bushes. An adjustable over-pressure relief valve with by-pass to suction side is mounted on the pump. Normal execution is horizontal. If required, vertical version for bulkhead or with pedestal.

Connection: suction and discharge socket on the same level (in-line). Bigger pump with SAE- or DIN-flanges, smaller pump with screwed sockets.

Temperature: max. 100 °C, special design up to 150 °C

Capacity range: 0,1 – 100 m³/h

Pump pressure: up to 25 bar, special design for hydraulic oil up to 250 bar

Shaft sealing: stuffing box, axial- or radial-sealing ring, mechanical seal

Materials:
 casing cast iron
 Gears and shaft annealed steel

Driver: electric motor, design form B3, B5 or V1
 (gasoline / diesel engine is also possible)

Direction of rotation: cw, if required: ccw



Gear pump

Gear pumps special design



for lubricating and non-lubricating fluid as well as for liquids with solids. The internal gear pump can be used for fluids of any viscosity, like solvents (1 mm²/s) or chocolate (max. 1000.000 mm²/s)

Capacity: up to 180 m³/h
Max. different pressure 16 bar
Viscosity: to over 1000.000 mm²/s
Temperature: from -60 °C to +300 °C

Power transmission: flexible coupling, motor power should be selected 20% more than pump requirement
Bearing: sleeve bearing
Suction lift: max. 5 m vacuum-metric
Viscosity/speed: depending on viscosities the following pump speeds have to be selected



viscosity approx.:	10 - 50°E	50 Hz 1500 l/min	60 Hz 1200 l/min
	50 - 200°E	1000 l/min	900 l/min
	200 - 300°E	750 l/min	600 l/min

The selfpriming positive displacement rotary pump for liquids of any viscosity used for example:

- | | | | |
|-------------|-------------------|-----------------|------------------|
| Aceton | Detergents | Laquer | Polyol |
| Acids | Diesel fuel | Lard | Printers ink |
| Alcohols | Ether | Liquefied gas | Resin |
| Alkalis | Fat | Lubricating oil | Soap |
| Asphalt | Freon | Methanol | Sodium silicate |
| Bitumen | Fruit juices | Milk | Solvents |
| Blood | Fuel oil | Milk of lime | Starch |
| Brine | Gelatine | Mineral oil | Syrup |
| Bunker fuel | Glue | Molasses | Tar |
| Chemicals | Glycerine | Must | Trichlorethylene |
| Chocolate | Glycol | Petrol | Varnish |
| Colours | Heat transfer oil | Petroleum | Viscose |
| Cream | Isocyanate | Pithc | Wax |
| Creosote | Kerosene | Plastifiers | Wine |

Screw-type pump with internal bearings

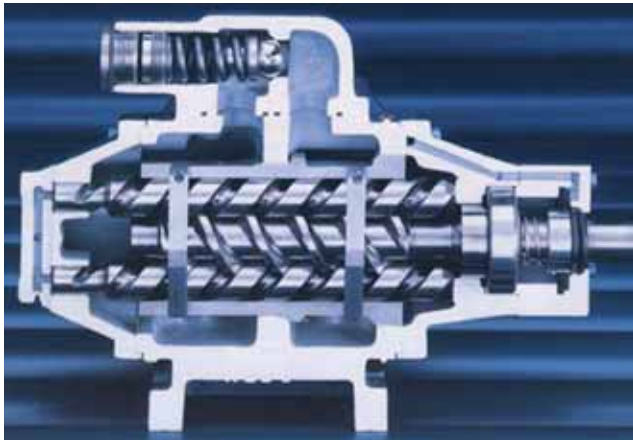

Application:

as fuel-oil supply-, ringline- and transfer pump. Lubricating oil supply and circulating pump, tank drain pump, cooling-oil and hydraulic pump. Generally applicable to self-lubricating liquids without any content of grinding particles.

- Design:** three spindle, self-priming screw pump for low noise and continuous flow. As over-pressure protection a safety valve is provided. The pump can be delivered with heating device electric or steam
- Connections:** suction and discharge on the same level (in-line).
- Temperature:** max. approx 150 °C (Please consider recommended inlet pressure for fuel pumps up to max. 150 °C)
- Pump pressure:** normal up to 16 bar, for medium with good self lubricating property higher pressures up to 100 bar are available.
- Capacity:** 0,5 – 250 m³/h



Screw-type pump with internal bearings

- Shaft sealing:** radial sealing ring, stuffing box, mechanical seal
- Materials:** casing: cast iron or spheroidal graphite iron
spindles: nitrided steel
- Driver:** electric motor, diesel engine, steam turbine, mechanically, electrically or hydraulically controlled variable speed drives, V-belt drive.
- Direction of rotation:** cw, special design: ccw
- Power transmission:** flexible coupling or V-belt drive.
- Bearings of the pump:** spindles are supported in replaceable bearing bushes or in bearing housings. A roller bearing on the drive end cover used for the axial fixing of spindle block. The axial thrust, which acts on the supply screws is hydraulically balanced.
- Suction lift:** max. 8 m vacuum metric depending on viscosity and speed

- Viscosity:** marine standard up to 760 cst



Vertical free-standing-design with pedestal



Horizontal design with base frame



Horizontal or vertical for bulkhead mounting

Screw-type pump with external bearings

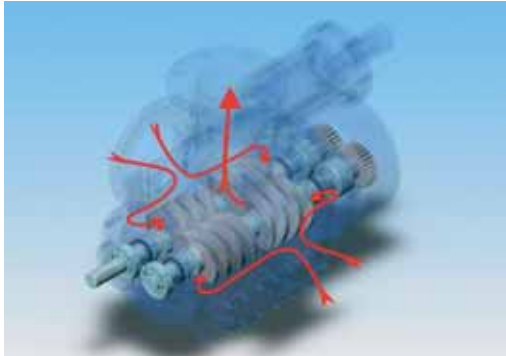

Application:	Marine:	as cargo pumps for the transfer of H.F.O., M.D.O. gasoline etc. as a coolant pump or lubrication pump for marine diesel engines, turbines and gearboxes, for ballast transfer
	Refinery:	for the transfer of mazut, waste oil, fuel oil, lubricating oil, turbine hydraulic and gear oil, naphta and bitumen
	Chemical industry:	for the transfer of thin, highly viscous, neutral or aggressive mediums.

Special feature: pump is able to pump non-lubricating medium such as for example water

Design: two spindle, self-priming screw pump for low noise and continuous flow. As over-pressure protection a safety valve is provided. The pump can be delivered with heating device for electric, steam and thermo oil

Connections: suction at both sides (big advantage), discharge at top

Temperature: max. approx 120 °C

Pump pressure: normal up to 16 bar, for medium with good self lubricating property higher pressures up to 100 bar are available.

Capacity: 10 – 1500 m³/h

Total head: up to 160 m

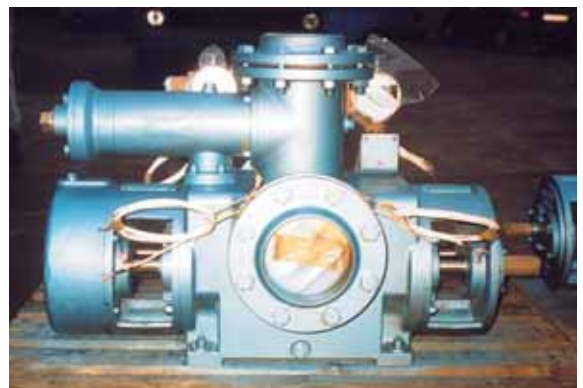

Horizontal design with temperature control for the bearings

Screw-type pump with external bearings

Shaft sealing: stuffing box, mechanical seal

Materials:

normal design: casing and screws
special design: casing: cast steel, steel welded, spheroidal graphite iron, bronze, aluminium and stainless steel

Driver: electric motor, diesel engine, steam turbine, mechanically, electrically or hydraulically controlled variable speed drives, V-belt drive.

Direction of rotation: cw or ccw

Power transmission: flexible coupling or V-belt drive.

Bearings of the pump: the bearings are arranged outside the supply room. Driving of the running spindle is driven via a cogwheel gearing.

Suction lift: max. 8 m vacuum metric depending on viscosity and speed

Viscosity: up to 15000 ° E or more, if a free flow of the liquid to the pump or a supply by a booster is ensured.

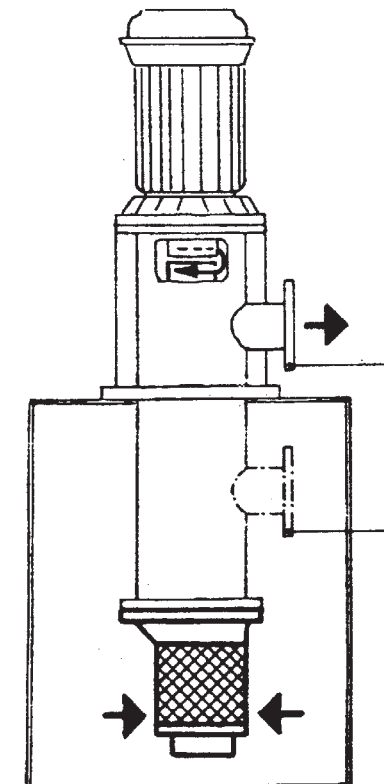

Eccentric helical rotor pump



Application:

Handling abrasive, neutral or aggressive liquids, the viscosity and consistency of which may be just fluid. Medium with fibrous content or containing very high proportions of solids, as well as gaseous, aerated and foaming compounds can also be pumped safely. This pump is used especially in food-, chemical-, ceramic-, cosmetic-, cellulose-, plastic-, soap- and fat-industry, agriculture, filter technique, ship-building, water treatment plants.

Design:

Horizontal or vertical self-priming eccentric helical rotor pumps. Stator and rotor (wearing parts) are replaceable.

Pump and motor are connected flexibly to each other and mounted on a common base plate. A relief valve must be provided on the discharge side of the pump if a shut-off valve is installed on pump outlet. If a dry running may occur the pump must be protected by separate equipment.

Connections:

suction socket	vertical upwards
discharge socket	axial
if direction of rotation changed	connections opposite

Pump with flange connections (smaller pumps with inner thread)

Temperature: max. 200° C

Capacity range: 0,1 – 600 m³/h

Delivery head: max. 400 m

Shaft sealing: stuffing box or mechanical seal



Eccentric helical rotor pump

Materials:

Casing: cast iron, steel, stainless steel or cast iron inside rubberized
 Rotor and shaft: stainless steel
 Stator: perbunan, natural rubber, neoprene, hypalon, silicon, buna, viton, polyethylene, polyamide, teflon etc.

Driver:

Electric motor, geared motor, infinitely variable gear, gasoline- or diesel-engine by means of flexible coupling. V-belt drive and chain drive.

Direction of rotation:

ccw (if required cw in this case suction axial, discharge vertical upwards)

Bearing:

Two grease lubricated ball bearings in bearing housing. The rotor is connected by two cardan joints and the universal joint with the drive shaft rotates. The cardan joints are necessary so that the rotary motion of the driver can be transmitted to the rotor which is eccentrically located in the stator.

Suction lift:

max. 8 m (depending on medium and viscosity)

Type of construction:

The pump can be delivered as express cleaning model; as vertical submerged model; as block pump and in many other special designs.



For pumping extremely viscous, pasty or hardly pumpable medium or medium with a content of solid matter (up to 60 % drying agent) on the universal joint a screw conveyor is mounted transporting this very viscous medium into the handling elements to avoid failure.

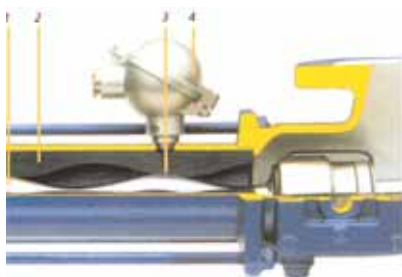

dry running protection

Pumps' special features for use in oil and gas installations on and offshore

flow rate: starting from 0.1 l/hr (0.026 usgph) for precise dosing of liquids with accuracies of $\pm 1\%$
 Volumes of 350 m³/h (1542 usgpm) at speeds of approx. 350 rpm can be achieved e.g. for transporting drilling mud, crude oil, etc.

pressure: up to 144 bar (2088 psi) can be achieved e.g. Down Hole Pump used in oilfield installations for oil extraction

API 373

pumps can be manufactured in accordance with API 676 "Rotary Positive Displacement Pumps"

Size reduction technique

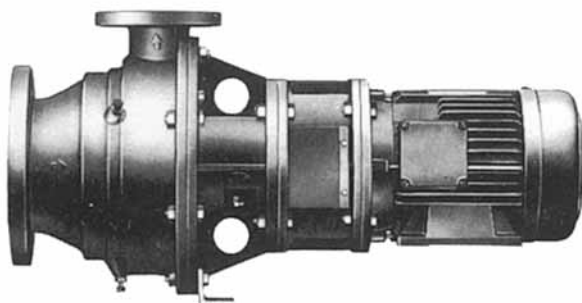

4

Application: Size reduction units chop solids conveyed in liquids like wood, textiles, plastics, paper, rubber, bones, skins, glass etc. and make them pumpable. After treatment the solids have a grain size of approx. 3,5 mm and fibres a size of approx. 1,5 cm². (As metal parts and stones destroy the cutting tools of the impeller, a collecting tank should be installed in front of a size reduction unit to separate them)

Design:

- Tank mounting:** for lateral installation to a collection tank or basin. These size reduction units work as disintegrator pump with a delivery head of 3 m and thus automatically lead back the chopped particles into the main flow.
- Pipeline mounting:** for direct installation into the piping. With this design the size reduction unit must be stopped by a helical rotor pump sucking the solids through the size reduction unit and pumping it into the plant for further treatment.
- Connections:** unit for tank mounting with axial pointed suction- and sideways pointed discharge socket.
unit for pipeline mounting = inline flange design
- Temperature:** max. 80 °C
- Capacity range:** 10 – 80 m³/h (max. through-put by sludge of 3 % dry substance)
- Shaft sealing:** mechanical seal, which must be supplied with seal water (2 bar above the system pressure)
- Driver, power transmission and bearing:**
- Tank mounting design:** electric standard motor, building form B 3 / B 5, ball bearing in bearing casing with flexible coupling
- Pipeline mounting design:** electric motor, building form V 1 with special bearing, because complete bearing from motor, motor shaft = pump shaft

Peristaltic pumps

Benefits at a glance:

- ideal for abrasive, viscous and shear sensitive media
- gentle pumping of liquid or viscous products
- constant volume capacity due to vacuum support
- dry running resistant
- integrated early warning system
- pumping of media with entrained solids
- unobstructed fluid flow – easy cleaning
- free of dynamic and pressure loaded seals
- infinite regulation of capacity
- easy operation and servicing, only one wear item

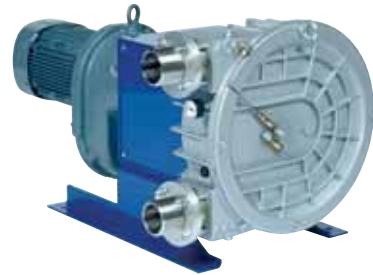

Main application: chemical industry, ceramic and porcelain industry, food and beverage industry, breweries, cosmetic and pharmaceutical industry, power stations, colour and painting industry, waste and disposal industry

Design: horizontal pump for electric drive or by gasoline or diesel engine

Bearing: ball bearings

Lubricant filling: silicon oil, glycerin

Materials: stainless steel, Polypropylene, PVDF

Hose: Natural Rubber (NR), Nitrile (NBR), Hypalone, Butyl, EPDM

Connections: male thread

capacity range: 0,1 – 25 m³/h

total head: max. 13 bar

suction lift: max. 9,5 m

Elastomers:
Natural rubber (NR)
Properties: tension-resistant, elastic, cold-resistant, approved for food applications
Operative range: for abrasive media, diluted acids and alkalis
Temperature range: - 20 °C - +80 °C

Nitrile rubber (NBR)
Properties: wear-resistant, grease and oil resistant
Operative range: for oily and greasy media, alcohols
Temperature range: -10 °C - +80 °C

Butyl rubber
Properties: heat resistant and non-aging, gas-tight
Operative range: for organic and inorganic acids alkalis, ketones and hot water
Temperature range: -25 °C - + 80 °C

Hypalon
Properties: chemical resistant, wear resistant
Operative range: for acids and alkalis, colours
Temperature range: - 20 °C - + 80 °C

EPDM
Properties: chemical resistant, good insulating properties and outside applications
Operative range: for acids and alkalis, hot water
Temperature range: - 30 °C - + 80 °C

Hand pump

semi-rotating wing pump

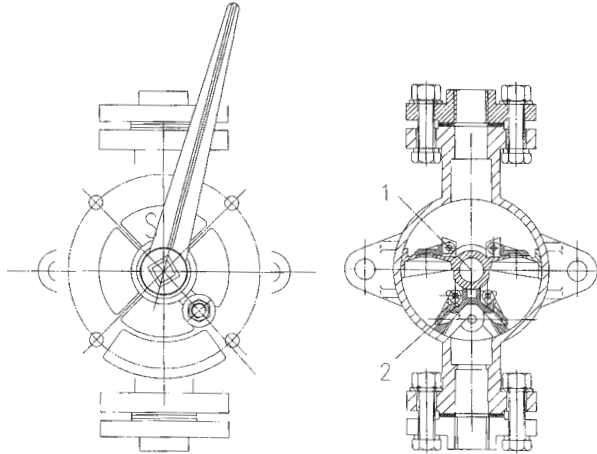

Function- and operating description

the function of the pump will be performed by moving the pump shaft by swinging the hand lever and the piston wing (1) with the integrated flaps in connection with the suction divider (2) and its integrated flaps, the medium will be sucked in and discharged. The integrated flaps in the suction divider (2) and the piston wing (1) will open under the left or right side of the pump. They will close by further strokes in the opposite direction by the medium when discharging.

In connection with the Semi-Rotating Piston Wing Pump and an electrical pump as compact

unit the discharged medium from the electrical pump passes through the piston wing pump and opens the flaps. As soon as the flow is interrupted the flaps will close and prevent the backflow. In this case the flaps are acting as a check valve.

4

Application: The pump is suitable for the following liquids: water, diesel fuel, bunker oil, alcohol, paraffine, all not aggressive liquids, greasing oil up to a viscosity of 40 °E, LPG with special shaft sealing, thermo oil in special design.

Pump features: piston wing conical, for safe operation and long life
 piston wing control flaps with grinded seat
 bronze bearing for shaft in body and cover
 o-ring sealing between cover and body
 material and material combination corrosion safe
 additional reinforced mounting possibility
 freezing safe for water application (drain screw)
 quality and function control for each pump
 for zero-leakage additional check valve integrated
 self-priming is guaranteed by integrated check valve

Materials: casing cast iron, piston wing and suction divider brass, bearing bronze
 for seawater we can deliver material bronze

Connection: oval flanges with counter flanges

Suction lift: max. 7 m

discharge head: max. 25 m

temperature: max 80 °C (special design up to 200 °C)

size No.	connection inch	capacity ca. l/min	number of strokes/min	weight ca. kp
00	3/8	7,5	80	3
0	1/2	11,5	65	4
1	3/4	17,25	60	6
2	1	22,5	55	8
3	1 1/4	29	50	10
4	1 1/4	43,25	50	12
5	1 1/2	53,5	45	15

Hand pump

Barrel pumps



suitable for standard 200 liter barrel

Material: cast iron,
PVC (for seawater)

Operation: hand level or
rotating actuator

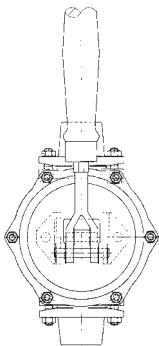

Diaphragm pump, suction and discharge pump casing
cast iron, diaphragm and ball valve made of rubber

Connection	1¼"	1½"
Capacity ca.	40 l/min	50 l/min
Delivery head ca.	15 m	15 m



Pressure- and test-pump

up to 50 bar pressure, with single piston, pump-casing made
of special casting, valves made of bronze, with shut-off valve,
drain valve, galvanized water reservoir and pressure gauge

Piston Ø	30 mm
Piston stroke	40 mm
Operation pressure	50 bar
Reservoir dimension	430 x 310 x 330 mm
Weight	14 kp

(with single piston available up to 100 bar, with double piston
up to 1000 bar)

Ejector

Application: **Bilge Ejector:**
for all sorts of bilges e.g. engine bilges, cargo hold bilges, chain lockers, peak tanks, sludge tanks, gutters, septic tanks, or for pumping soot deriving from boiler cleaning, sludge from cargo hold cleaning

Stripping ejector:
i.e. for stripping out the remaining oil (-sludge) in cargo tanks and other tanks

Portable ejector:
with hose connections to be used where fixed installations are lacking

Cleaning ejector:
with hoses for vacuum-cleaning or cargo-holds

Evacuating ejector:
for evacuating air, e.g. from a central vacuum tank (priming ejector)

Materials: bronze, cast iron, cast steel, stainless steel

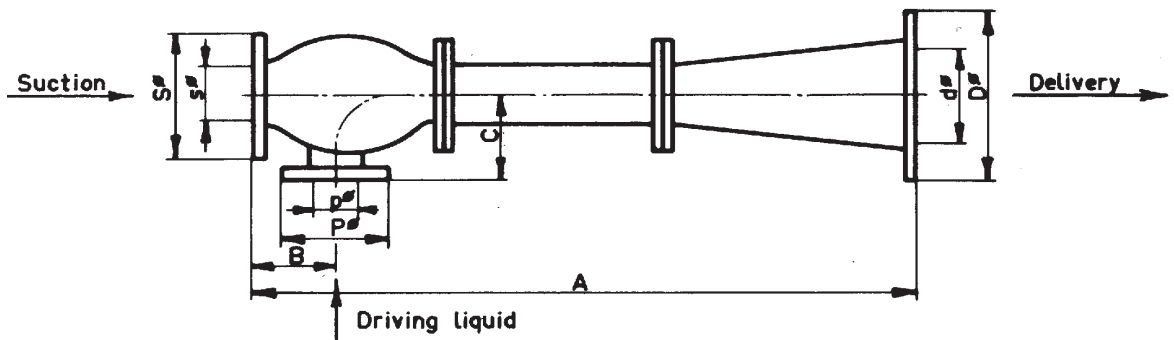

Ejector type	A	B	C	pØ	PØ	sØ	SØ	dØ	DØ	Kgs
25- 50- 40	385	40	39	1" BSP socket	2" BSP socket	1 1/2" BSP nipple	2			
25- 50- 50	456	40	39	1"	2"	2"	3			
40- 70- 70	600	60	70	1 1/2"	2 1/2"	2 1/2"	10			
50- 80- 80	794	115	130	50	165	80	200	80	200	35
50- 80- 100	940	115	130	50	165	80	200	100	220	46
70- 100- 100	965	123	138	70	185	100	220	100	220	47
70- 100- 125	1230	123	138	70	185	100	220	125	250	62
100- 100- 125	1230	124	153	70	185	125	250	125	250	64
100- 125- 150	1265	124	153	70	185	125	250	150	285	66
125- 150- 150	1238	162	180	125	250	150	285	150	285	125
125- 150- 200	1606	162	180	125	250	150	285	200	340	155
150- 200- 200	1855	180	215	150	285	200	340	200	340	220
150- 200- 250	1905	180	215	150	285	200	340	250	395	230
200- 250- 250	2190	230	250	200	340	250	395	250	395	260
200- 250- 300	2295	230	250	200	340	250	395	300	445	290
250- 300- 350	2510	280	275	250	395	300	445	350	505	485

Ejector

Sizes and capacities axial suction, sideways driving liquid injection

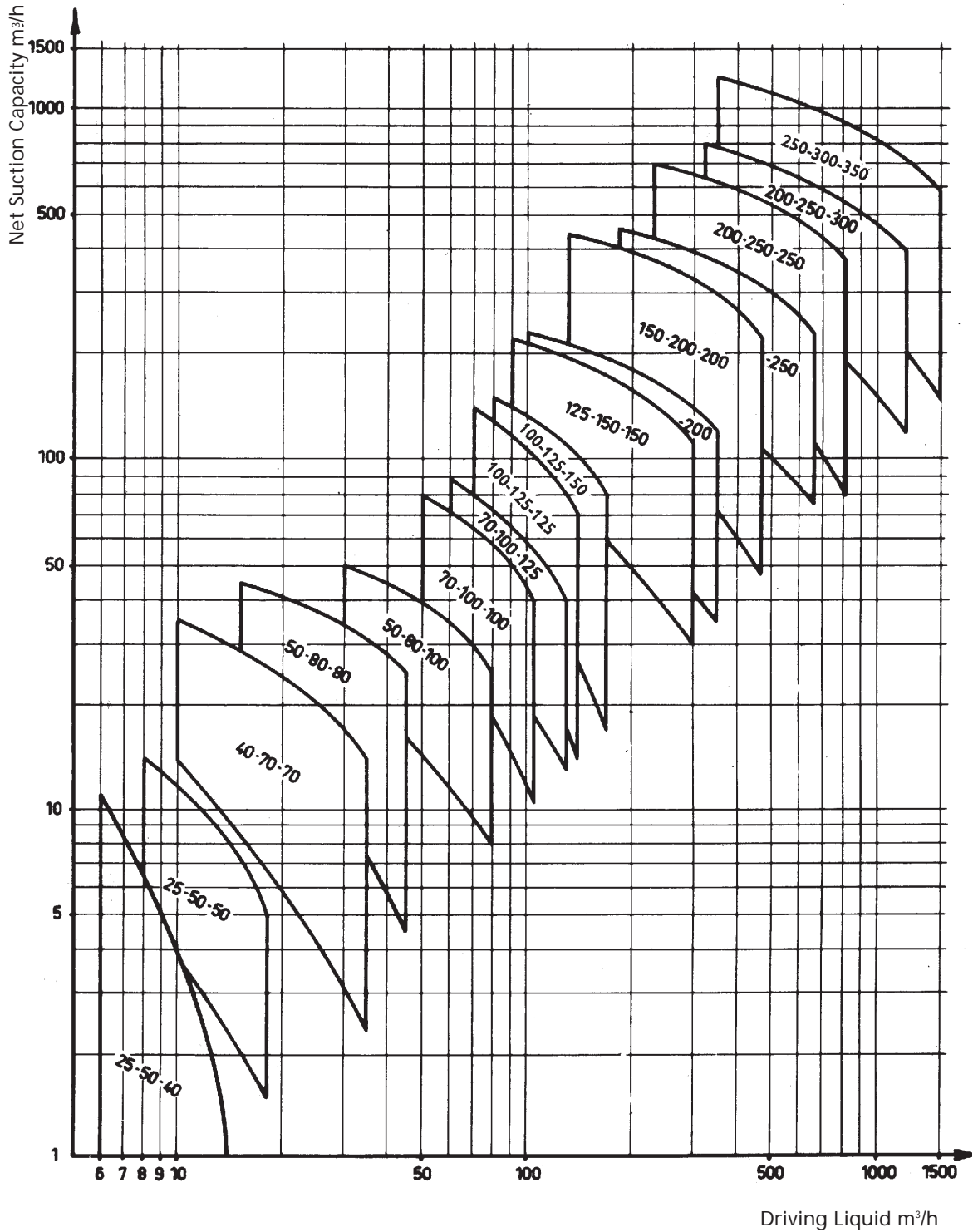

VN - Pumpen

Pumps

Ejector

Total heads -
 μ relations rough estimate

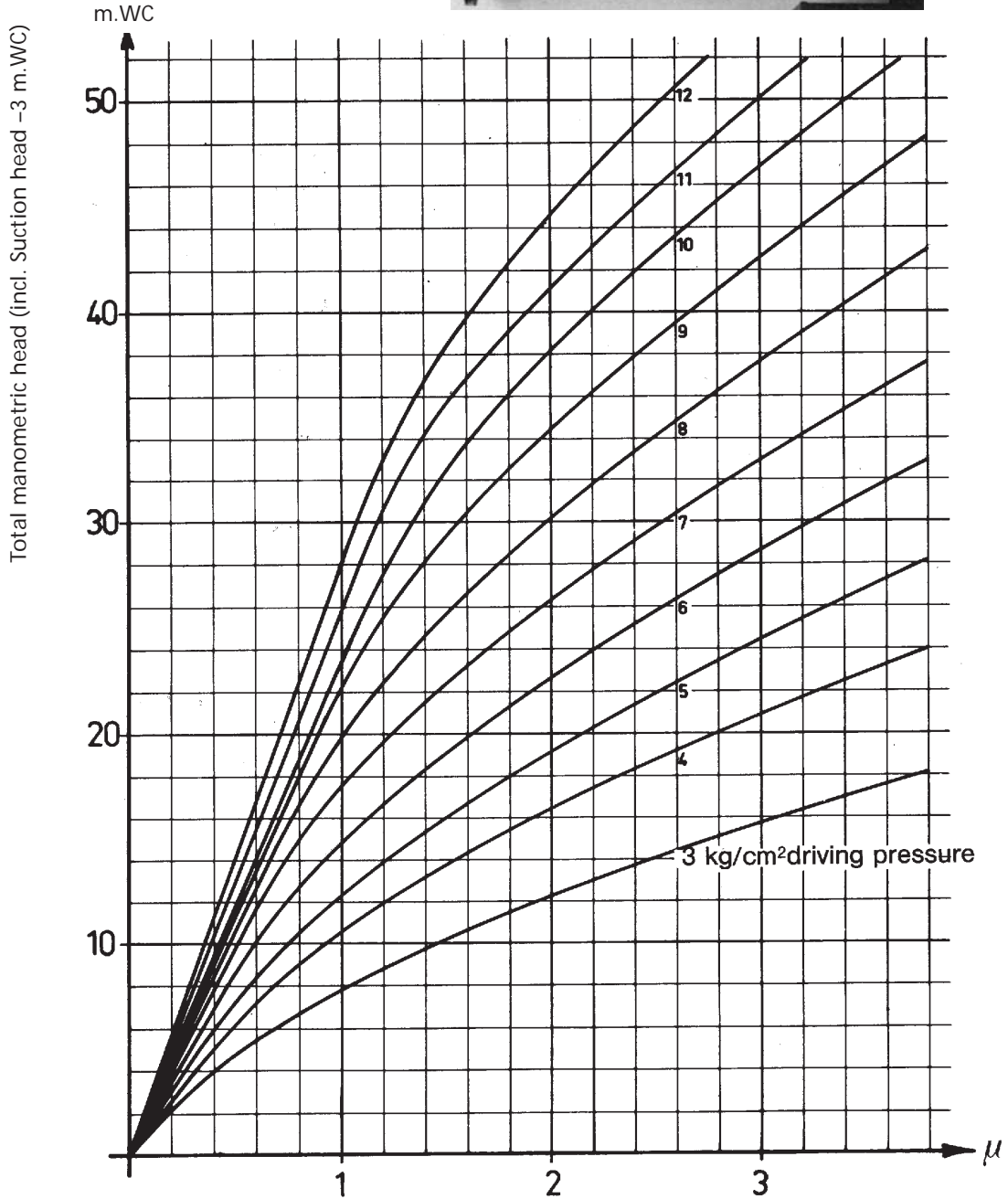

$$\mu = \frac{\text{driving liquid}}{\text{net suction capacity}}$$

Curve gives a rough estimate on the applicability of your requirements.

Example: Required capacity/head: 200 m³/h - 15 m W.C.

Driving pressure available: 7 bar

From curve (15 m + 7 bar): $\mu = 0,8$

Driving liquid injection needed: 200 m³/h x 0,8 = 160 m³/h.