

# VN - Pumpen

Marine pumps and equipment

Cargo screw pump electric driven with gastight bulkhead gland



3



1

## Marine pumps and equipment

### Power transmission systems with gastight bulkhead and/or deck glands between engine rooms and pump rooms

The shaft transmissions with gastight bulkheads and/or deck glands have been developed for small and medium size tankers for the power transmission from driving engines in the engine-room to cargo pumps in the pump room. A suitably designed flange with centering ring enables the mounting of the transmission on the deck or bulkhead. The shaft of the gastight bulkhead gland is equipped with two grease lubricated roller bearings (at each side one bearing) and sealed by means of an oil reservoir, which is mounted approx. 0,50 – 0,75 m above the shaft centreline. Other kinds of special seals such as radial seal rings and single or double mechanical seals, can be delivered on request. The transmission with gastight glands are designed according to the latest rules of the classification societies and can be delivered with type-test certificates from ABS, BV, DNV, GL, L.R.o.S. and R.I.N.A.

3

### Driving arrangements for cargo pumps (mainly for smaller tankers)

- Electric motor or diesel engine as prime mover for cargo pump

Normally a flexible coupling will be installed between the electric motor (or diesel engine) and the transmission shaft and a flexible coupling will be installed between the transmission shaft and the cargo pump. The length piece of the spacer coupling, if required, enables an easy dismantling of the cargo pump, motor or gastight bulkhead gland, if the bearings have to be renewed (see sketch).

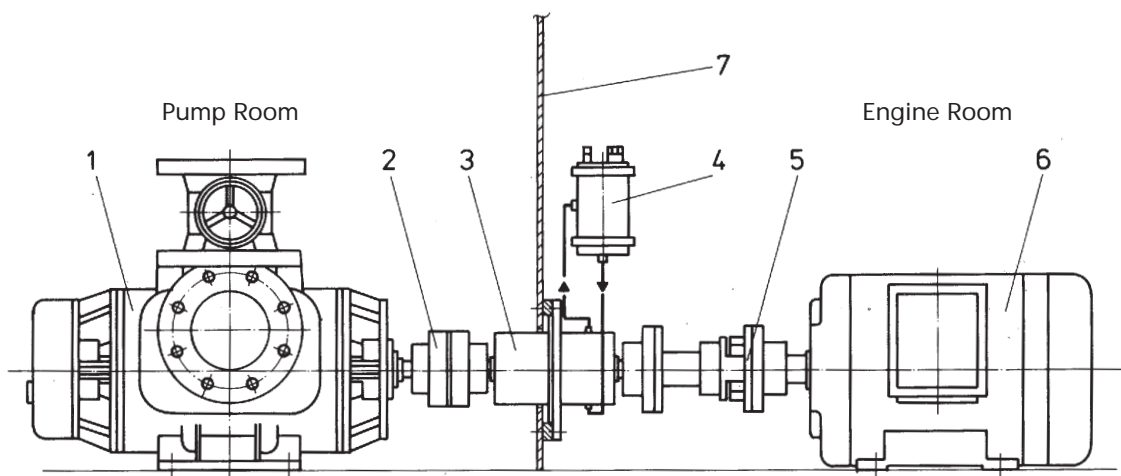

- 1) screw pump
- 2) flexible coupling
- 3) gastight bulkhead gland
- 4) oil reservoir
- 5) flexible coupling
- 6) electric motor
- 7) bulkhead



## Marine pumps and equipment

Power transmission systems with gastight bulkhead and/or deck glands between engine rooms and pump rooms

### - Diesel engine as prime mover for cargo pump and generator

If a diesel engine is provided as driver, which will also be used for generator-drive and/or as main power source, then a highly elastic coupling with a clutch has to be installed between diesel engine and gastight bulkhead gland (see sketch).

The combination of a highly elastic coupling with a manually or pneumatically operated clutch ensures relatively short mounting lengths and will be preferred especially on small tankers. A spacer type flexible coupling will be recommended for the installation between gastight bulkhead gland and cargo-pump in this arrangement too. The system arrangement from diesel engine power take-off to the cargo pump driving shaft will be selected by us and a torsional vibration calculation will be carried out to ensure the proper operation of the selected system components.

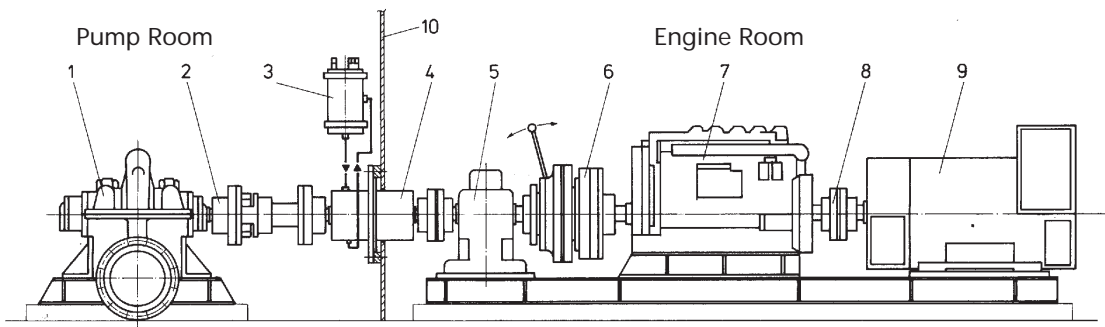

- |                             |                      |
|-----------------------------|----------------------|
| 1) centrifugal pump         | 6) clutch            |
| 2) flexible spacer-coupling | 7) diesel engine     |
| 3) oil reservoir            | 8) flexible coupling |
| 4) gastight bulkhead gland  | 9) generator         |
| 5) gear box                 | 10) bulkhead         |

The complete system can be delivered with a certificate of a classification society.

In cases where a speed reduction or a speed increase is necessary, a reduction gear or a speed-up gear will be delivered.

Power transmission systems with gastight bulkhead glands are available for pump capacities up to 1000 m<sup>3</sup>/h – at 10 bar. Shaft transmission torques up to 5500 N/m – larger transmissions can be delivered on request.

If you submit your pump transmission problems, we will prepare a complete transmission proposal to you with alternative solutions.

# VN - Pumpen

Marine pumps and equipment

## Combined units



Marine diesel engine with generator and self priming fire extinguishing pump, with clutch

3



Marine diesel engine with high pressure compressor and cargo screw pump with clutch



Electrically driven cooling water and ballast pumps with clutches

4

# VN - Pumpen

Marine pumps and equipment

## Combined units

Marine diesel engine with generator and general service pump with clutch



3



Marine diesel engine with generator and hydraulic power package

Marine diesel engine with generator and fire extinguishing pump with clutch



5

# VN - Pumpen

Marine pumps and equipment

## Vertical centrifugal pumps



### Centrifugal pump with spacer coupling

vertical, non-selfpriming, single stage, in-line.  
Through usage of spacer coupling the complete bearing unit including impeller can be dismantled without removing casing and motor.

#### Application:

Cooling water pump  
Circulating pump  
General service pump\*  
Fire extinguishing pump\*  
(\*flooded)

$Q = 10 - 800 \text{ m}^3/\text{h}$   
 $H = 10 - 95 \text{ m}$



### Centrifugal pump short version

vertical, non-selfpriming, single stage, in-line

The impeller can be dismantled without removing piping and casing.

#### Application:

Cooling water pump  
Circulating pump  
General service pump\*  
Fire extinguishing pump\*  
(\*flooded)

$Q = 10 - 250 \text{ m}^3/\text{h}$   
 $H = 10 - 95 \text{ m}$

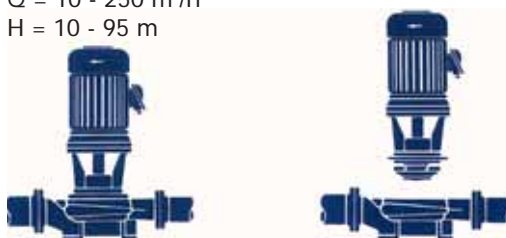

Selfpriming centrifugal pump as ballast-, bilge-, fire extinguishing- and general service pump with evacuating device as described on pages 8 + 9

# VN - Pumpen

Marine pumps and equipment

## Marine pumps and equipment



Vertical with lower axial inlet and radial outlet

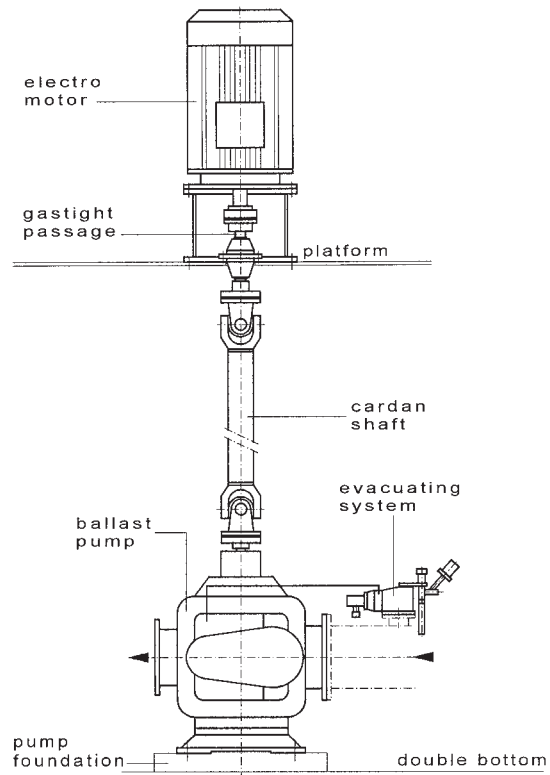

Axial splitted ballast pump with selfpriming device and gastight deck gland with cardan shaft

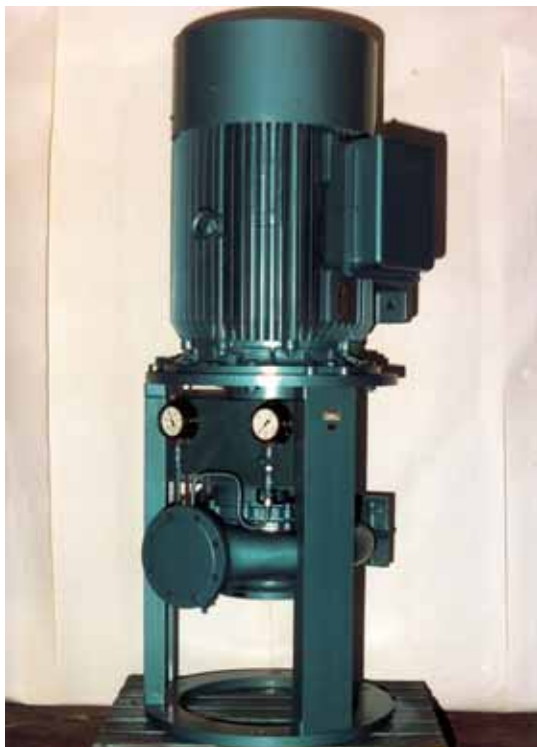

Marine centrifugal pumps as

- cooling water-pumps
- bilge-pumps
- ballast-pumps
- general service-pumps
- fire extinguishing pumps
- (evacuating devices see pages 8 + 9)

# VN - Pumpen

Marine pumps and equipment

## Priming Systems for Marine Pumps

Examples from our Scope of Supply

The priming system of a centrifugal pump is an independent component part of the total pumping system arrangement. Besides the size of the pump it is also critical to the selection of the suitable system whether the pump mainly has to be evacuated before starting (e.g. pumps working from sea water tank) or whether during and at the end of the pump operation air/gas has to be discharged from the system (e.g. bilge, ballst or cargo pumps)

with Pressure Air Ejectors

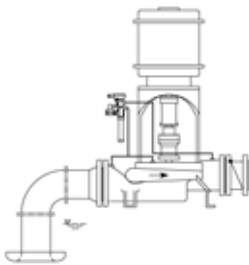

Type AELD



with Liquid Ring Vacuum Pumps



Type ASGB

Centrifugal pumps that mainly have to be evacuated before starting may be equipped with attached pressure controlled priming systems.

Example: pumps working from the sea water tank.

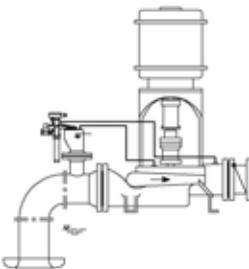

Type AELC



Type ASGL



Pumping systems that have to be primed also during operation may be equipped depending on the volume of air intake with pressure control priming systems. These are installed on the suction line in front of the pump.

Example: smaller bilge and ballast pumps.

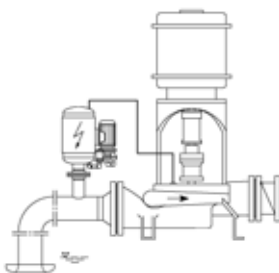

Type AELG



Type ASVA/B



Pumping systems where larger amounts of gas volume have to be evacuated during pump operation requires level controlled priming systems. These have to be installed in front of the centrifugal pump too.

Example: larger bilge and ballast pumps

## Priming Systems for Marine Pumps

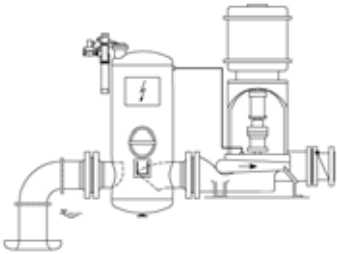

Type AELH



Type ASVS



Pumping systems where large amounts of gas volumes have to be evacuated during and especially at the end of pump operation are to be equipped with level controlled priming systems which enable efficient separation of gas from the discharge liquid

Example: larger bilge and ballast pumps or cargo pumps with stripping function.

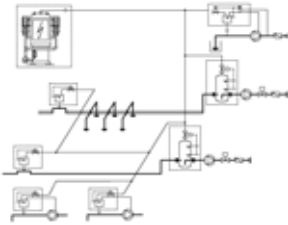

Type AELZ



Type TDV



Central vacuum system enables the connection of several centrifugal pumps. Each linked centrifugal pump is equipped with a pressure level controlled gas discharge valve which will be selected based on the above mentioned requirements.

Type GAE



Type GAC



Type SLE



# VN - Pumpen

Marine pumps and equipment

## Horizontal centrifugal pumps:



**Centrifugal pump, non-selfpriming**  
horizontal, single stage, acc. to DIN 24255  
with flexible coupling on common base  
plate or as bloc-pump for vertical bulkhead  
mounting

**Application:** Cooling water pump  
Air conditioning pump  
Circulating pump  
Fire extinguishing pump

Q = 5 - 500 m<sup>3</sup>/h  
H = 10 - 130 m

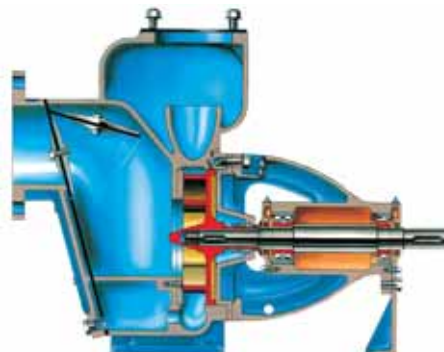

**Centrifugal pump, selfpriming**  
horizontal, single stage with flexible coupling  
on common base plate or as bloc-pump

**Application:** Ballast pump  
Bilge pump  
Fire extinguishing pump  
General service pump

Q = 2 - 250 m<sup>3</sup>/h  
H = 7 - 80 m



**Side channel pump, selfpriming**  
horizontal, single- or multistage, oval flanges  
with flexible coupling and mounting brackets

**Application:** Hydrophore pump  
Condensate pump  
Cooling water pump

Q = 0,5 - 7 m<sup>3</sup>/h  
H = 15 - 80 m

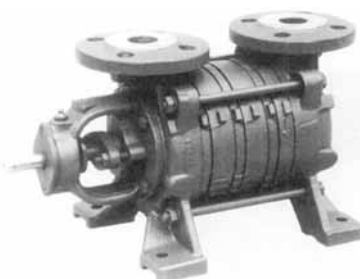

**Side channel pump, selfpriming**  
horizontal, single- or multistage, round flanges  
with flexible coupling on common base plate

**Application:** Hydrophore pump  
Condensate pump  
Cooling water pump

Q = 0,5 - 30 m<sup>3</sup>/h  
H = 15 - 150 m



**Centrifugal pump selfpriming**  
horizontal, single stage, with manual  
clutch for direct or V-belt drive

Q = 0,5 - 50 m<sup>3</sup>/h  
H = 5 - 50 m

# VN - Pumpen

Marine pumps and equipment

## Condensate pumps:



**Centrifugal pump**  
horizontal, single stage, non-selfpriming with mechanical seal

**Application:** Exhaust gas boiler circulating pump

Q = 3 - 50 m<sup>3</sup>/h  
H = 1 - 8 bar + inlet pressure  
T = up to 200 °C (without external cooling up to + 185 °C)



**Centrifugal pump**  
horizontal or vertical, multistage, non-selfpriming

**Application:** Boiler feed water pump

Q = 1 - 80 m<sup>3</sup>/h  
H = 8 - 30 bar

## Reciprocating pumps:



**Reciprocating piston pump**  
vertical, duplex, double acting, selfpriming

**Application:** Bilge- and Ballast pump  
Stripping pump

Q = 5 - 200 m<sup>3</sup>/h  
H = 20 - 80 m



**Piston pump**  
horizontal, with gear, double acting, selfpriming

**Application:** Bilge pump  
(can be delivered with ball valves as Sludge pump for dirty and slightly viscous liquids)

Q = 0,5 - 30 m<sup>3</sup>/h  
H = 15 - 60 m

# VN - Pumpen

Marine pumps and equipment

## Positive displacement pumps:



### Screw pump

vertical or horizontal 3-spindle, internal bearings, selfpriming, with built-in relief valve

**Application:** HFO or MDO transfer pump  
Lub oil transfer pump  
Lub oil pump  
Oil service pump  
Hydraulic pump  
Cargo pump  
Fuel oil booster pump

Q = 0,5 - 400 m<sup>3</sup>/h  
H = 0,5 - 16 bar



### Screw pump

vertical or horizontal 2-spindle with external bearings, twin-gear

**Application:** Cargo- and Stripping pump for:  
Products, crude oil, chemicals, highly viscous liquids i.e. Molasses, Asphalt etc., and water

Q = 10 - 1500 m<sup>3</sup>/h  
H = 2 - 25 bar



### Gear pump

vertical or horizontal, internal bearings, selfpriming, with built-in relief valve

**Application:** HFO or MDO transfer pump, Lub oil transfer pump, Lub oil pump, Oil service pump, Hydraulic pump, Cargo pump, Fuel oil booster pump

Q = 0,1 - 250 m<sup>3</sup>/h  
H = up to 16 bar (bigger pump, with external bearings, up to 1200 m<sup>3</sup>/h can be used as cargo pumps)



# VN - Pumpen

Marine pumps and equipment

## Positive displacement pumps:



**Excentric helical rotor pump**  
horizontal or vertical, selfpriming, Stator and Rotor (wearing parts) are replaceable

**Application:** Sludge pump  
Bilge pump  
and for highly viscous liquids

Q = 0,1 - 600 m<sup>3</sup>/h  
H = up to max. 40 bar

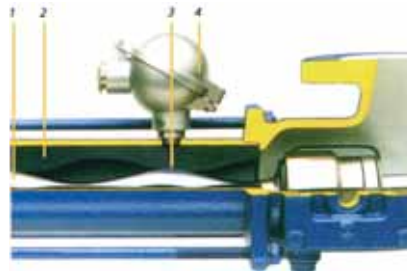

Can be delivered with dry-running protection which continuously monitor the temperature in the stator and stop the pump when reaching the limit temperature.

3

## Sewage pumps:

**Centrifugal pump**  
single stage, vertical for dry- or wet installation, dryrunning-proof. Handling of liquids with admixtures/solids up to the size of discharge socket.

**Application:** Sewage and Bilge.  
Also for process deck of fish-trawlers

Q = corresponding to size of solids  
(i.e. 150 mm = approx. 250 m<sup>3</sup>/h, 950 1/min)  
H = approx. 4 m  
Q = 10 - 500 m<sup>3</sup>/h  
H = 2 - 40 m

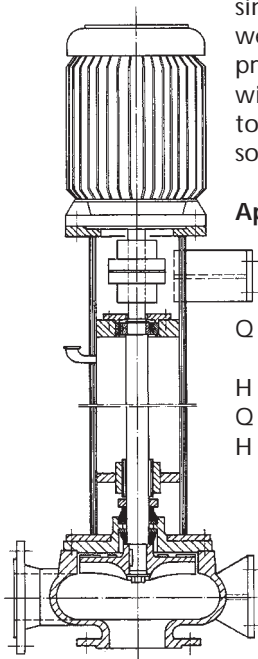

**Centrifugal sewage pump**  
horizontal or vertical, single stage, one-channel or open impeller, automatic cutting device, non-selfpriming.  
Q = 5 - 150 m<sup>3</sup>/h  
H = 3 - 60 m

Also available as submersible design as bilge pump. Material cast iron, aluminium, bronze, stainless steel

**Application:** Bilge /sewage/fecal pump

Q = 5 - 200 m<sup>3</sup>/h  
H = 1 - 40 m



# VN - Pumpen

Marine pumps and equipment

Compact unit consisting of:

Hydrophore, Filter, Sterilization and Calorifer

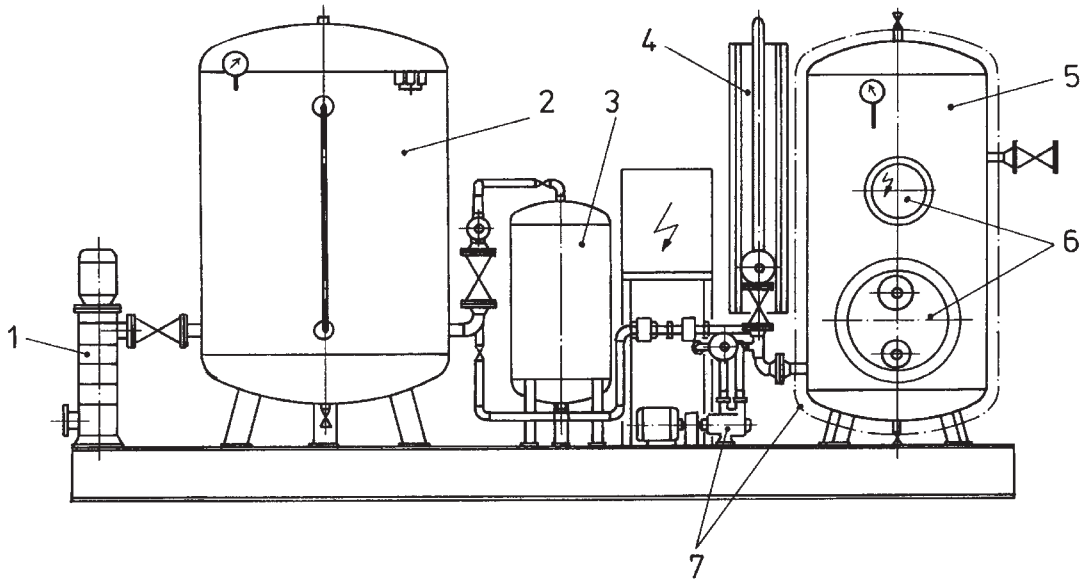

Range of components assembled acc. to your requirements, piped and wired ready for operation on common base frame.

- |                          |   |
|--------------------------|---|
| <b>Hydrophore pumps:</b> | 1 or 2 piston- or self-priming centrifugal pumps (1)  |
| <b>Pressure Vessel:</b>  | galvanized steel or inside coated, or with copper inside or made of stainless steel (2)   |
| <b>Armatures:</b>        | brass, bronze, cast iron or rubberized  |
| <b>Piping:</b>           | galvanized steel, copper, stainless steel or PVC  |
| <b>Filter:</b>           | multiple layer drinking water treatment filter with activated dolomite and hydro-anthracite (3)   |
| <b>UV-dosages:</b>       | ultra-violet disinfection of water (4)  |
| <b>Calorifer:</b>        | galvanized steel or inside coated, or with copper inside or made of stainless steel (5)   |
| <b>Heating:</b>          | with electric heating flange and/or with steam heating coil (6).<br>Accessories for heating steam regulating, circulating pump (7)<br>etc. Insulation will be included automatically. |

# VN - Pumpen

Marine pumps and equipment

## Hydrophore compact units



Compact units consisting of hydrophore, filter, sterilization and calorifer



# VN - Pumpen

Marine pumps and equipment

## Hydrophore compact units

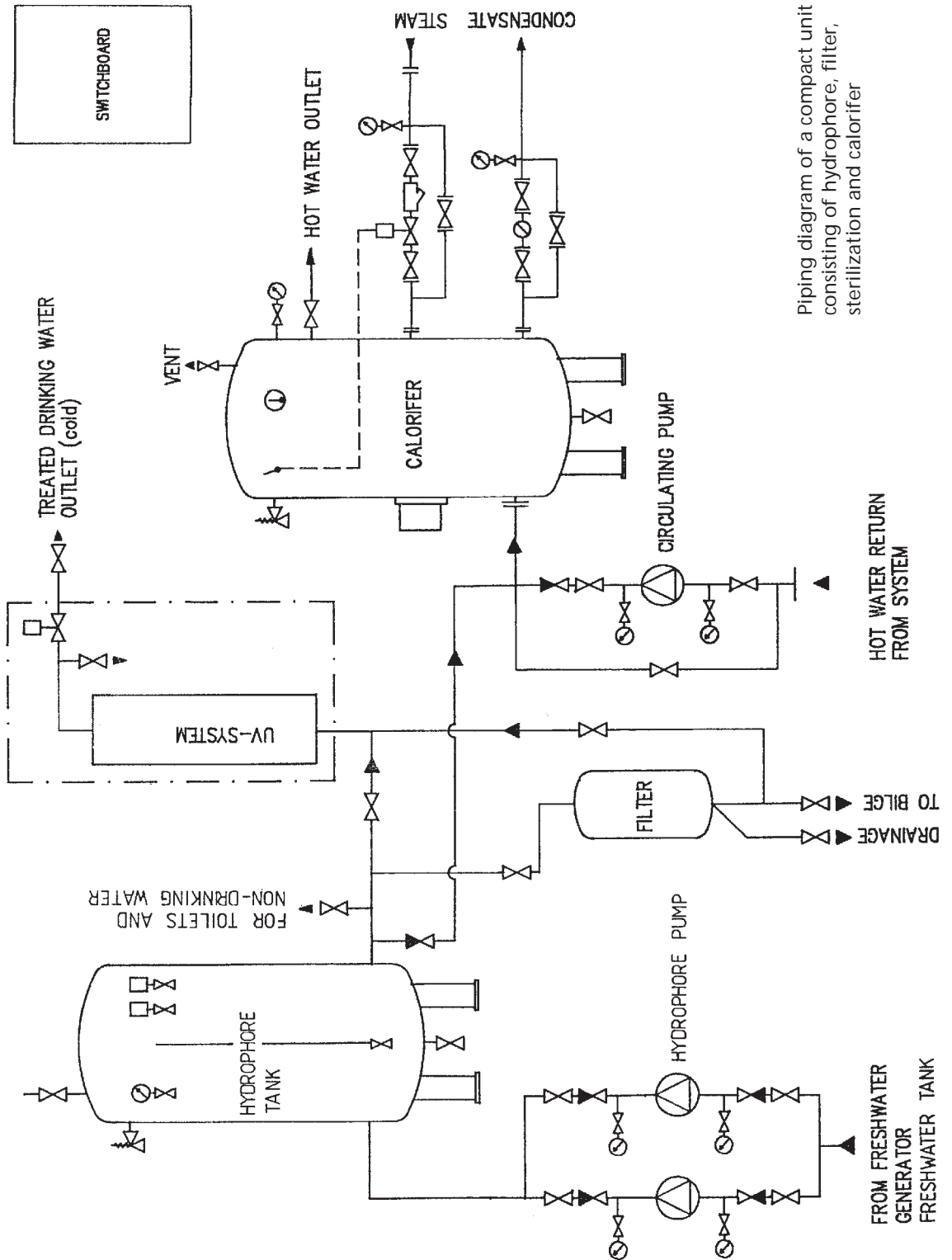

Piping diagram of a compact unit consisting of hydrophore, filter, sterilization and calorifer

# VN - Pumpen

Marine pumps and equipment

## Hydrophore compact units



3



Compact units consisting of hydrophore, filter, sterilization and calorifer

## UV-Disinfection:

### Features and advantages of UV-sterilizing plants:

- Ultraviolet rays destroy all harmful germs immediately.
- No chemicals or other substances are added to the water.
- Neither the chemical composition nor the taste or smell of the water is altered by UV treatment.
- UV disinfection, by its nature, presents no risk of over-dosage.
- UV units operate on a very low current consumption. Running costs and maintenance requirements are negligible.

3

### The standard units for the capacities 3 m<sup>3</sup>/h, 5m<sup>3</sup>/h and 9 m<sup>3</sup>/h distinguish themselves by:

- Compact shape - little space needed
- Fully preassembled and ready wired for instant switch-on
- Radiation chamber of steel pipe 1.4571 material (equals V4A, AISI 316)
- Perfected high intensity UV-radiator with guaranteed service life
- Novel quick service aqua jacket sealing - easy to handle for inspection - no fracture risk
- UV-monitoring system with pre-alarm
- Easy, single wall mounting of switchboard and chamber, no fixing devices needed

### Fields of application:

- communities
- industrial plants
- on board of seagoing vessels
- household
- sanitary sector deep wells
- airconditioning/air washer sector
- water treatment plants
- service water disinfection (rain water cisterns, etc.)

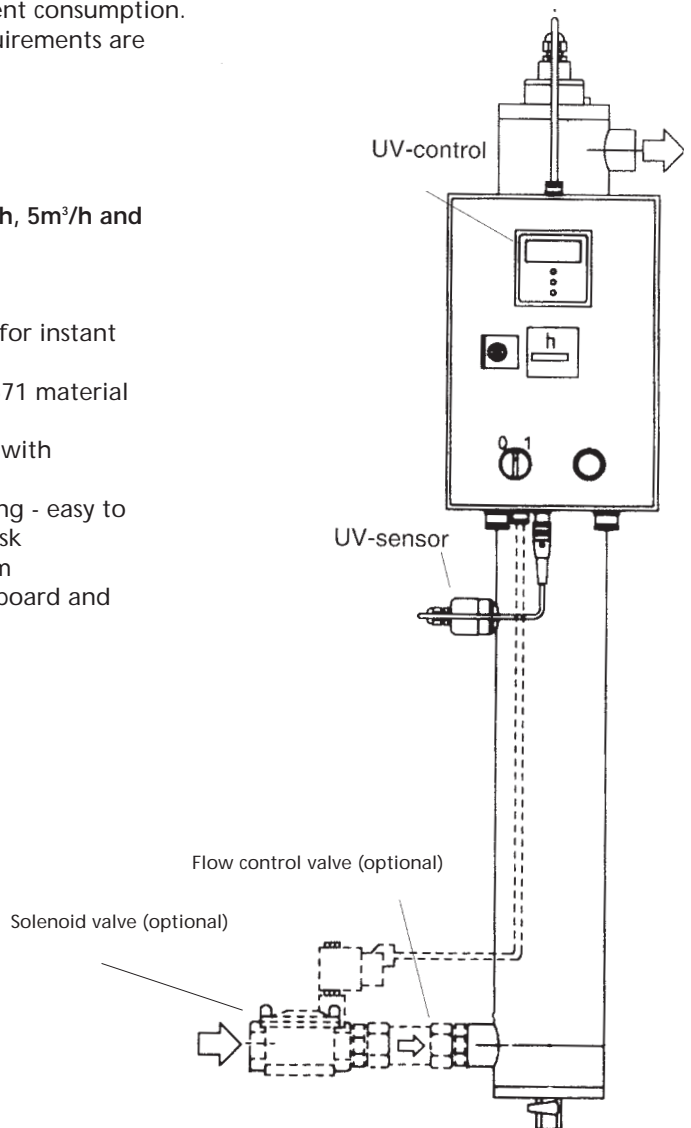

UV-sterilization plant available for higher capacity

## Multiple drinking water treatment filter

The aggressive carbonic acid contained in the distillate reacts on filtering with activated dolomite to calcium- and magnesium bicarbonate. The pure water is only delivered with substances that are accepted in accordance with the "Regulations about the Addition of External Substances on preparing of Drinking Water" (Drinking Water Treatment Regulation) issued on December 19, 1959 and in accordance with DIN 2000 and DIN 2001.

On applying activated dolomite for the reharding of the distillate the hardness increases by approx. 1 ° dH/10 g carbonic acid bound off. In order to make up a working cost calculation, it can be estimated with sufficient accuracy that by using of 10 g carbonic acid bound off, approx. 13 g of activated dolomite material will be consumed. The rehardening comes up to approx. 2 - 3 ° dH. The consumption of activated dolomite material will be approx. 50 - 70 g/t distillate. The operating time is approx. 1000 h until refilling is needed.

As activated dolomitic material acts sensitively when in contact with iron and manganese compounds, there is a layer of hydro-anthracite included to maintain its deacidizing function. In parallel, hydro anthracite is also used to improve the taste of the drinking water, as distilled water is likely to have a rotten taste.

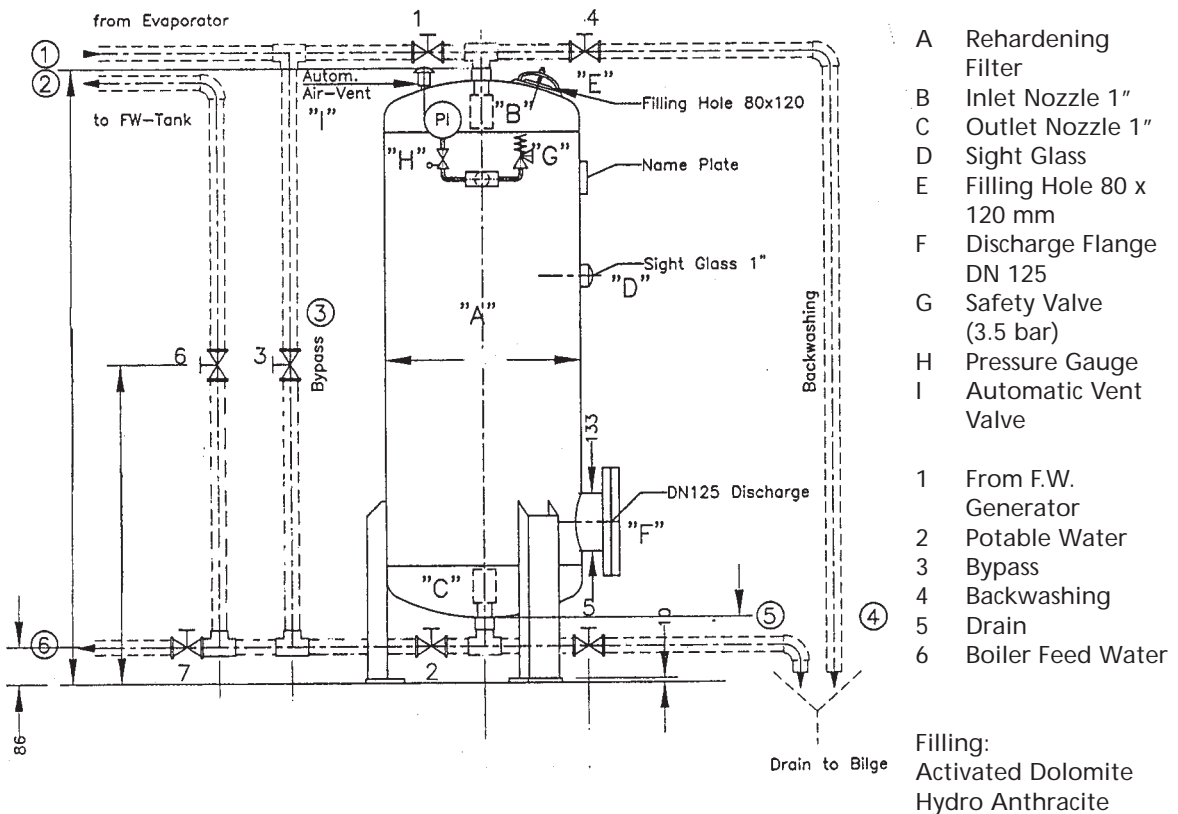

Valve Position	1	2	3	4	5	6	7
Operation	x	x	-	-	x	-	-
Backwash	-	x	x	x	-	-	-
Bypass	-	-	x	-	-	x	-
Drain	-	-	-	-	x	-	-
Boiler Feed	-	-	x	-	-	-	x

# VN - Pumpen

Marine pumps and equipment

## Waterworks with piston pump

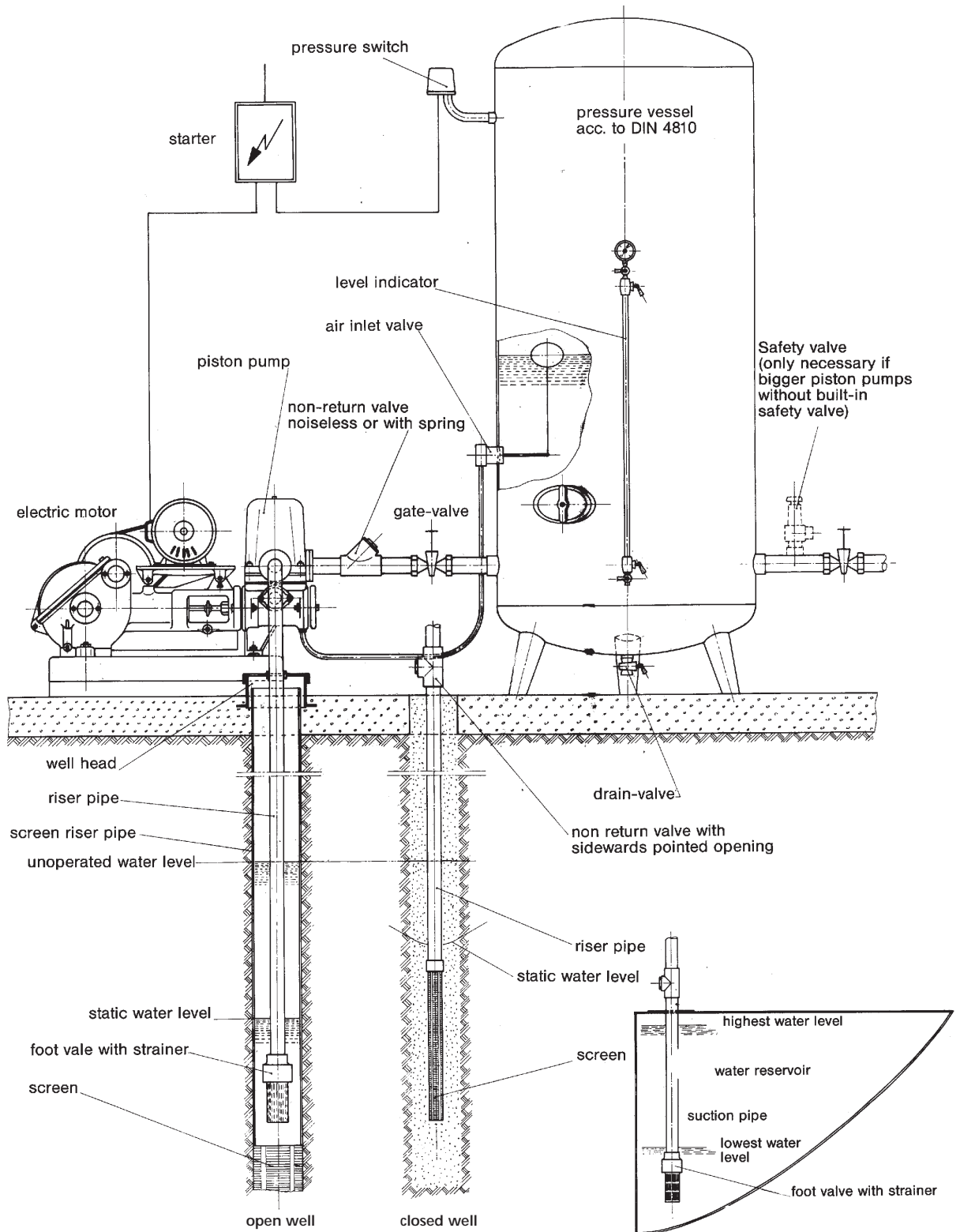

# VN - Pumpen

Marine pumps and equipment

## Waterworks with selfpriming centrifugal pump

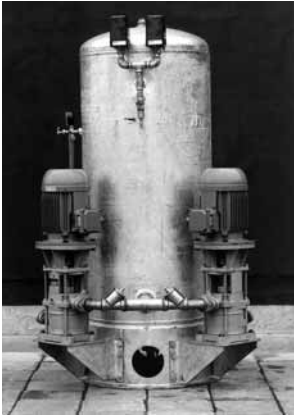

Can be delivered as compact

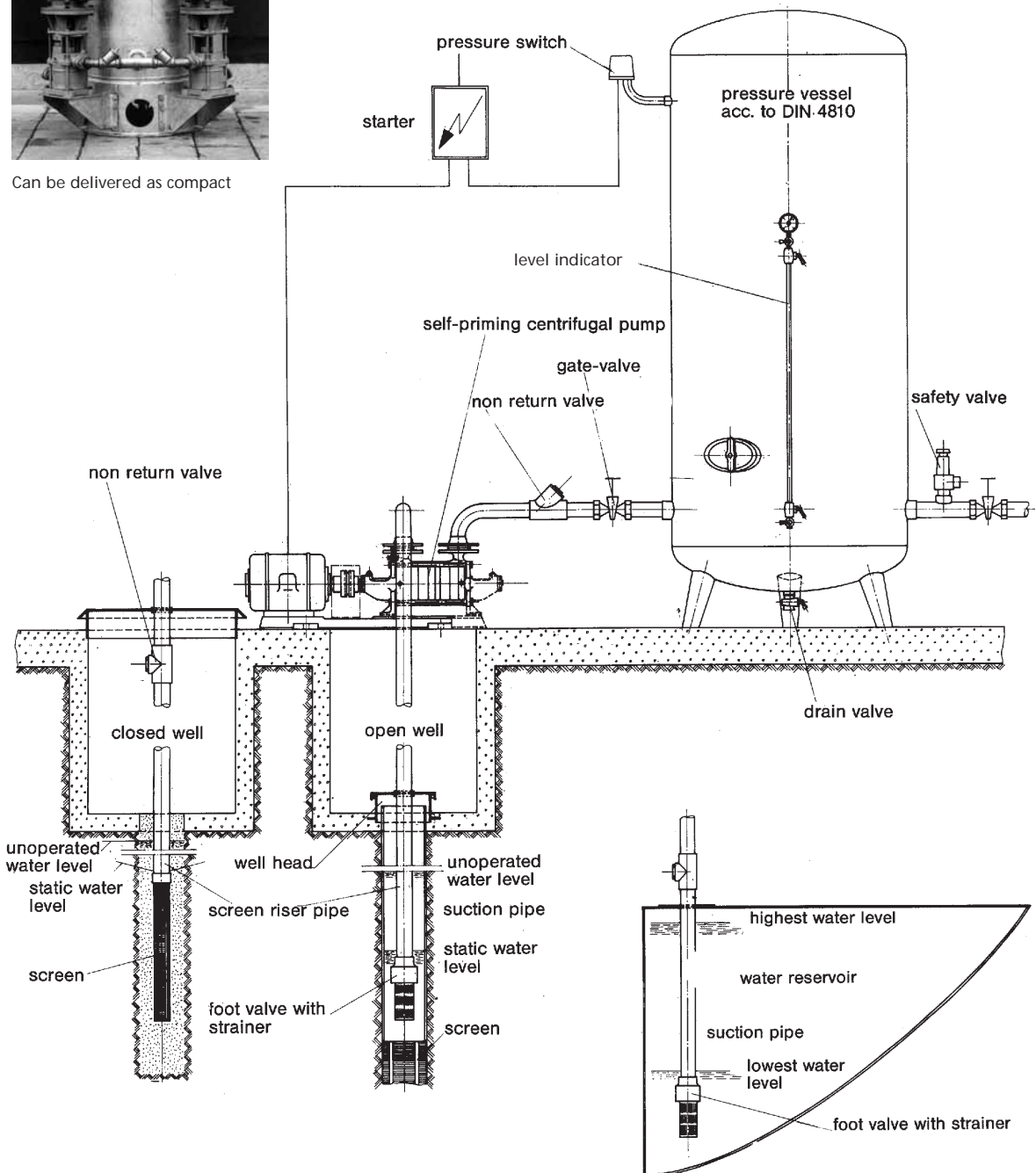

# VN - Pumpen

Marine pumps and equipment

Working air compressors  
Oilfree compressors  
Emergency compressors



## Miscellaneous

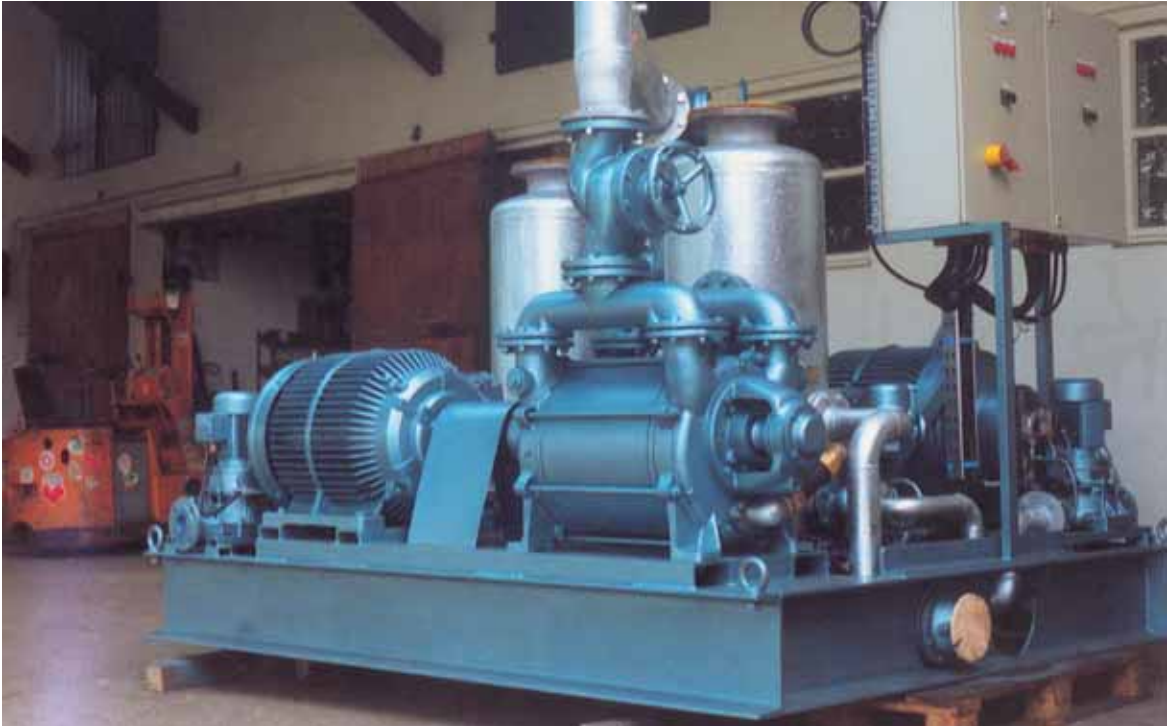

3

Vacuum compact unit for a painting vessel



Bilge pump unit DC-motor and starter



Special sewage pumps with vortex-impeller for big solids

## Cargo pump installation

### How the system works:

Standard operation will take place from the control room  
Current setting and feedback signal are visual on control panel  
The speed from the cargo pump can be manually reduced locally

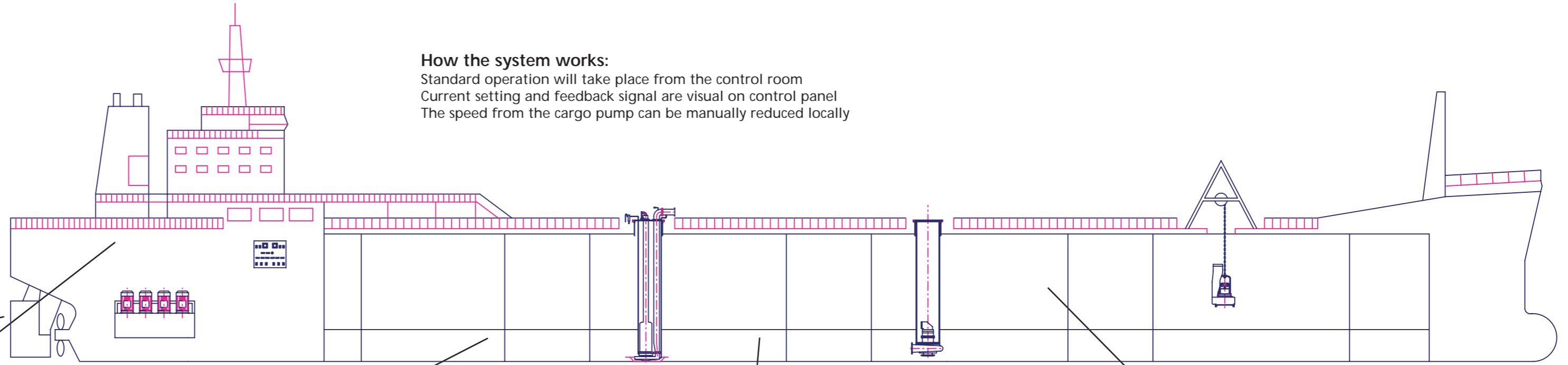

**HYDRAULIC POWER-PACK:**

**CONTROL UNIT:**

**HYDRAULICALLY-DRIVEN DEEPWELL PUMPS:**

**SELFPRIMING BALLASTPUMPS:**

**HYDRAULICALLY-DRIVEN TRANSPORTABLE PUMPS:**

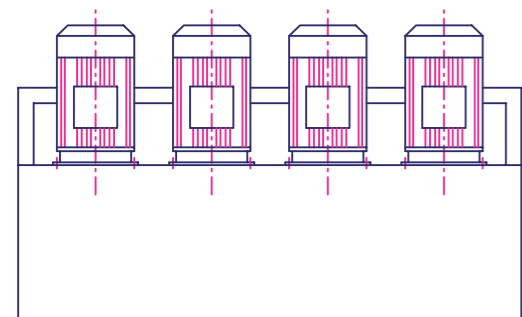

Hydraulic power-pack, consisting of electrically-driven pressure-controlled hydraulic pumps, fullflow high- and low pressure filters, oil cooler, filling unit and control unit.

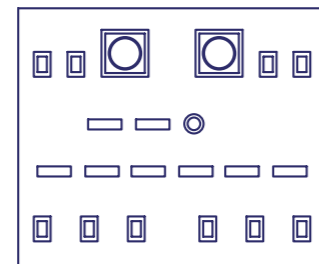

Can be delivered either with:

- traditional direct control with pilot lines, gauges etc.
- electrically-operated proportional valves
- IQAN controlled integrated computer system

The complete system is made of standardized components (hydraulic components) which are available from stock worldwide. Also technical support is available via the Parker-Denison organization.

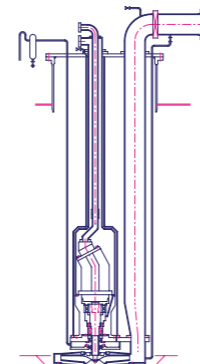

Deepwell cargo pump, consisting of pumpend with high-efficiency impeller, PTFE seals and pumphousing. Hydraulic motor is protected by means of a shell with cofferdam with sealleakage system, preventing hydraulic oil from getting into contact with cargo being pumped. Pipestack will be produced according to the required length complete with top plate and deck trunk. Delivery will be complete with a suction well, designed for the best stripping efficiency. Top plate will be delivered with a hydraulic control valve which optimises pump discharge rate depending on the cargo pump's discharge pressure. Also any deepwell pump is equipped with an emergency stop button and hand operated valve for local control and stripping. Materials for the cargo pumps are AISI-316 and PTFE. Capacity range from 50 to 1100 m<sup>3</sup>/hr at max. pressure of 130 mlc.

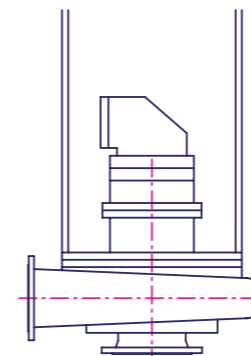

Ballast pumps are fully submerged hydraulically-driven pumps in ballast tanks, produced in AISI-316 with bronze impellers, capacities up to 2000 m<sup>3</sup>/hr, discharge heads up to 40 mlc.

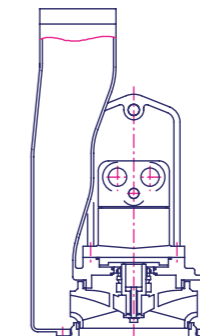

Will be used as a transportable emergency off-loading pump, suitable to enter standard 12" but-terworth holes. Capacities up to 500 m<sup>3</sup>/hr, discharge pressures up to 70mlc. Can be driven from Ship's hydraulic system or with a transportable hydraulic power-pack, elec-tric- or diesel engine driven.

# VN - Pumpen

Marine pumps and equipment

## How the Cargo pump works:

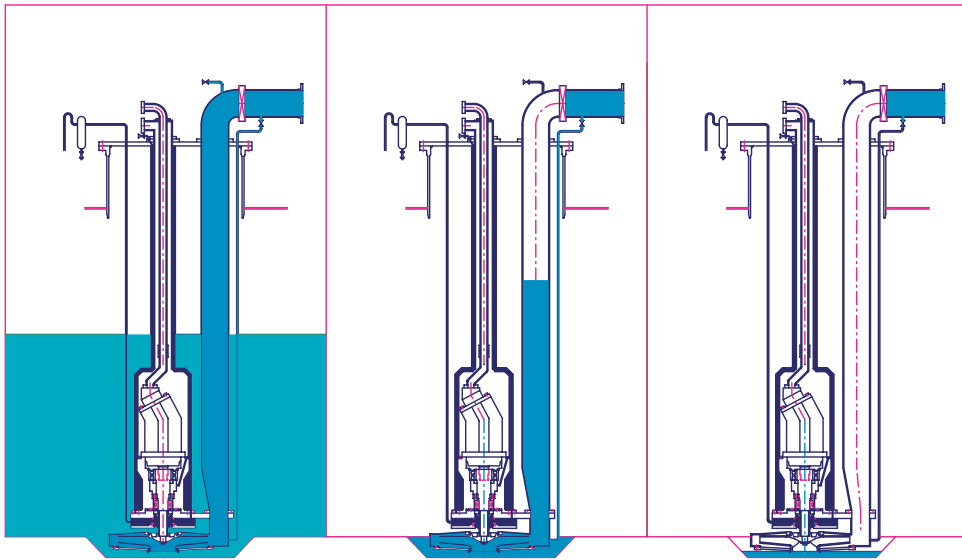

3

### Sketch -1-

Discharging of cargo via discharge piping at always the maximum capacity possible, caused by using the pressure-controlled hydraulic system delivered by the power-pack.

### Sketch -2-

Stripping will be done by using air, nitrogen or inert gas to pressurize the discharge pipe with the pump impeller (acting as a check valve) at a low speed, contents of the discharge pipe will be discharged via the stripping line.

### Sketch -3-

Remains of suction well and stripping line will meet Solas regulations.

# VN - Pumpen

## Cargo pump installation



3

### Delivery:

Pre-assembled  
Tested and set at requirements  
Easy to install

### Installing:

Central connection to pipe work  
Central connection to power supply  
Central connection control system

### Operation:

Windows program  
Control panel where required  
BUS-system to components

### Controlling:

Indicators where necessary  
On-line system control possible  
On-line trouble shouting possible

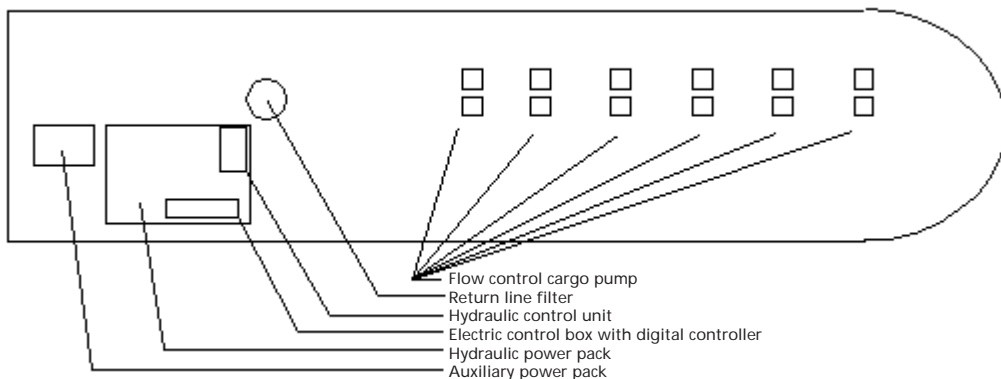

### Maintenance:

The system is set up for maximum liability operation.

Maintenance is reduced to a minimum.

All used components are "standard" components, this means that when a problem occurs, spare parts can be bought locally. With the extra On-Line control, trouble-shooting can be done "on-line".

## Biological sewage treatment plants

### Sewage treatment

Systems type tested and approved in accordance with IMO Resolution MEPC. 2 (VI) by the relevant authorities. Compact skid mounted units with all necessary accessories ready for operation with high performance up to 1000 persons

### Grease traps

For galleywater for removal of oil and fat as pretreatment before the sewage treatment plant

### Grey water treatment

Disinfection and membrane filtration for clean water discharge

### Vacuum systems

For black water, and vacuum valves for grey water and urinals



## Oily water separator

Oily water separator SKIT/S-DE in accordance with the recent IMO Resolution MEPC.107(49) consisting of a combination of the well known oily water separator SKIT/S, gravity coalescer type and a second stage new developed emulsion breaking, oil and hydrocarbon adsorber. The oily water separating systems will be equipped with a 15 ppm oil content alarm device, type tested and approved in accordance with IMO Resolution MEPC.107(49). A 3-way diverting valve will be activated by the alarm device, if necessary in accordance with MARPOL and class requirements. The system comes as a complete package, skid mounted with all necessary accessories and controls.

Q = 0.5 - 10 m<sup>3</sup>/h

3



## HFO Booster Modules

Today all the ships are using heavy fuel oil high viscosity and bad quality due to the fuel price and the owners' need for low cost operation.

The only way to ensure proper treatment of fuel oil and to protect the main and auxiliary engines is to install in the fuel oil system the equipment for heavy oil fuel conditioning. To reduce the building cost of the ships, shipyards are requesting that all of the equipment required for the conditioning/treatment of HFO be installed on one unit/module.

The Heavy Fuel Booster Module is the complete solution for fuel oil treatment between the daily service tanks and main propulsion as well as auxiliary engines.

The philosophy of the system is to have a self-contained unit provided with all the equipment required, as requested by the customer, ensuring trouble-free operation with a minimum of installation and adjustment work. This approach demands a high degree of flexibility for the mechanical as well as the electrical equipment when designing the module.

The modules are designed according to:

- Engine maker's requests and shipowner's operational standards
- Specific Engine Room design requirements
- Simple installation (all connections made according to particular engine room layout, easy to mount and to put in function).

Before delivery all the modules are fully tested and certified in presence of requested Class Surveyor.

## Fuel oil treatment

Supply of fuel oil with adequate cleanliness, pressure and viscosity to consumer (engine)

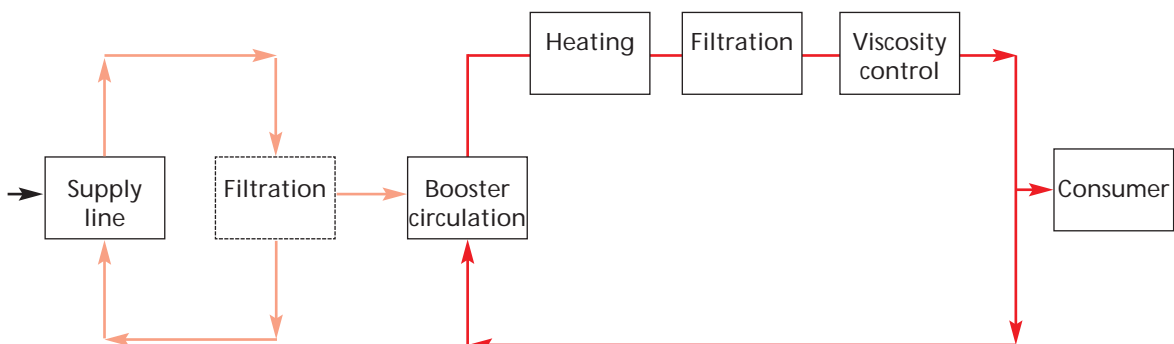



# VN - Pumpen

Marine pumps and equipment

## HFO Booster Modules



F.O. Booster unit for M.E.



F.O. Booster unit for M.E.

# VN - Pumpen

Marine pumps and equipment

## HFO Booster Modules

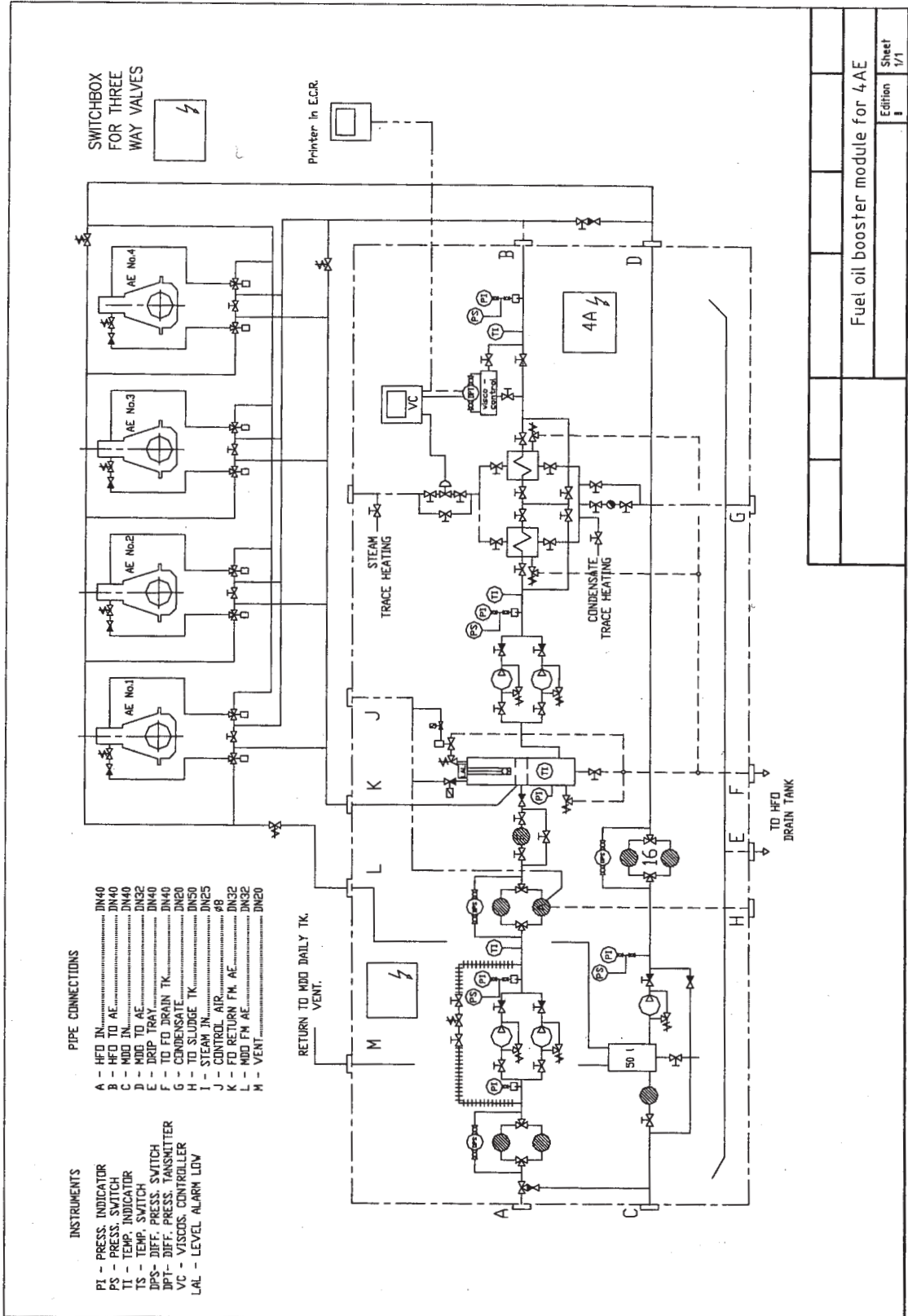

## HFO Booster Modules



F.O. Booster unit for A.E.



F.O. Booster unit for A.E.

# VN - Pumpen

Marine pumps and equipment

## HFO Booster Modules

3



Turbocharger lubrication oil module



Turbocharger lubrication oil module

Fuel oil conditioning unit  
for boiler's burner

